

MENIIT

NEET | IIT-JEE | FOUNDATION

Corporate Office: 44-A/1, Kalu Sarai, New Delhi 110016 | Web: www.meniit.com

JEE Advanced : Paper-2 (2018)

IMPORTANT INSTRUCTIONS

1. This section contains SIX (06) questions.
2. Each question has FOUR options for correct answer(s). ONE OR MORE THAN ONE of these four option(s) is (are) correct option(s).
3. For each question, choose the correct option(s) to answer the question.
Answer to each question will be evaluated according to the following marking scheme:
Full Marks: +4 If only (all) the correct option(s) is (are) chosen.
Partial Marks: +3 If all the four options are correct but ONLY three options are chosen.
Partial Marks: +2 If three or more options are correct but ONLY two options are chosen, both of which are correct options.
Partial Marks: +1 If two or more options are correct but ONLY one option is chosen and it is a correct option.
Zero Marks: 0 If none of the options is chosen (i.e. the question is unanswered).
Negative Marks: -2 In all other cases.

PART – A-PHYSICS

1. A particle of mass m is initially at rest at the origin. It is subjected to a force and starts moving along the x -axis. Its kinetic energy K changes with time as $dK/dt = \gamma t$, where γ is a positive constant of appropriate dimensions. Which of the following statements is (are) true?
- (A) The force applied on the particle is constant
 (B) The speed of the particle is proportional to time
 (C) The distance of the particle from the origin increases linearly with time
 (D) the force is conservative

Ans. [ABD]

Sol. $\frac{dK}{dt} = \gamma t$

$$\int dK = \int \gamma t dt$$

$$K = \frac{\gamma t^2}{2} = \frac{1}{2}mv^2$$

$$\Rightarrow v \propto t$$

$$\frac{dx}{dt} = \sqrt{\frac{\gamma}{m}} t \Rightarrow x = \sqrt{\frac{\gamma}{m}} \frac{t^2}{2}$$

$$P = \frac{dK}{dt}$$

$$Fv = \gamma t$$

$$F = \frac{\gamma t}{v}$$

Since $v \propto t$

So, F is constant

Hence it is conservative.

Option (A, B, D)

2. Consider a thin square plate floating on a viscous liquid in a large tank. The height h of the liquid in the tank is much less than the width of the tank. The floating plate is pulled horizontally with a constant velocity u_0 . Which of the following statements is (are) true?
- (A) The resistive force of liquid on the plate is inversely proportional to h
 (B) The resistive force of liquid on the plate is independent of the area of the plate
 (C) The tangential (shear) stress on the floor of the tank increases with u_0
 (D) The tangential (shear) stress on the plate varies linearly with the viscosity η of the liquid

Ans. [ACD]

Sol. $F - F_v = 0$

$$F = F_v = \eta A \frac{u_0}{h}$$

$$\sigma_s = \frac{F}{A} = \eta \frac{u_0}{h}$$

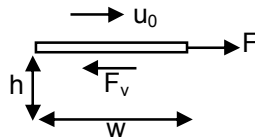

Option (A, C, D)

3. An infinitely long thin non-conducting wire is parallel to the z-axis and carries a uniform line charge density λ . It pierces a thin non-conducting spherical shell of radius R in such a way that the arc PQ subtends an angle 120° at the centre O of the spherical shell, as shown in the figure. The permittivity of free space is ϵ_0 . Which of the following statements is (are) true?

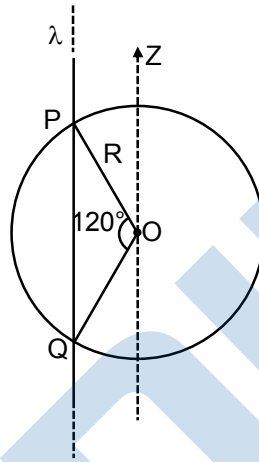

- (A) The electric flux through the shell is $\sqrt{3}R\lambda/\epsilon_0$
- (B) The z-component of the electric field is zero at all the points on the surface of the shell
- (C) The electric flux through the shell is $\sqrt{2}R\lambda/\epsilon_0$
- (D) The electric field is normal to the surface of the shell at all points

Ans. [AB]

Sol. $PM = R \sin 60^\circ = \frac{\sqrt{3}R}{2}$

$$PQ = 2PM = \sqrt{3}R$$

$$\phi = \frac{q_{enc}}{\epsilon_0} = \lambda \cdot \frac{\sqrt{3}R}{\epsilon_0}$$

Due to infinite wire (charged)

Electric field is perpendicular to its length.

Since shell is non-conducting, there is no electrostatic shielding & hence electric field is not normal.

Option (A, B)

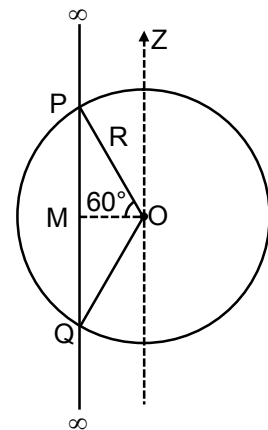

4. A wire is bent in the shape of a right-angled triangle and is placed in front of a concave mirror of focal length f , as shown in the figure. Which of the figures shown in the four options qualitatively represent(s) the shape of the image of the bent wire? (These figures are not to scale)

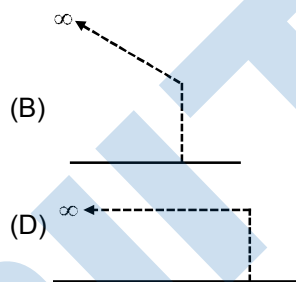
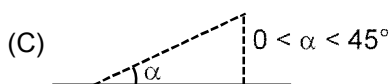
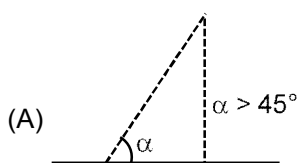
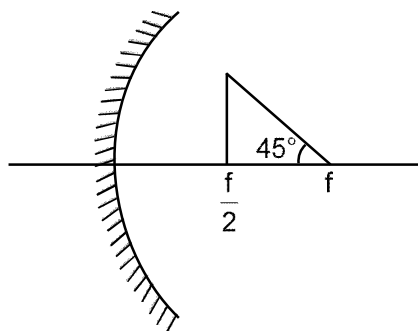

Ans. [D]

Sol. For 'P' (general point)

$$m = \frac{h_i}{x} = \frac{f}{f-u} = \frac{f}{x} > 0 \Rightarrow \text{virtual image}$$

$\Rightarrow h_i = f$ is independent of x .

\therefore possible option is (D)

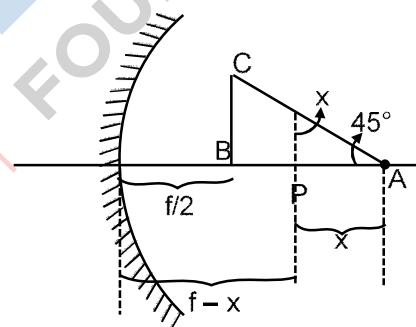
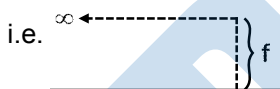

But even this option is justified for paraxial rays only, which isn't the case, in this question.

Moreover option (B) is also possible if observer is positioned on the line AC extended.

5. In a radioactive decay chain, ${}_{90}^{232}\text{Th}$ nucleus decays to ${}_{82}^{212}\text{Pb}$ nucleus. Let N_α and N_β be the number of α and β^- particles, respectively, emitted in this decay process. Which of the following statements is (are) true?

- (A) $N_\alpha = 5$ (B) $N_\alpha = 6$ (C) $N_\beta = 2$ (D) $N_\beta = 4$

Ans. [AC]

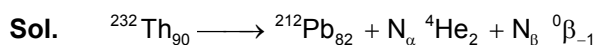

Using conservation of atomic and mass number

$$90 = 82 + 2N_\alpha - N_\beta$$

$$2N_\alpha - N_\beta = 8 \dots (1)$$

$$232 = 212 + 4N_\alpha \Rightarrow N_\alpha = 5$$

From (1) $N_\beta = 2$

So, option (A) & (C)

6. In an experiment to measure the speed of sound by a resonating air column, a tuning fork of frequency 500 Hz is used. The length of the air column is varied by changing the level of water in the resonance tube. Two successive resonances are heard at air columns of length 50.7cm and 83.9 cm. Which of the following statements is (are) true?

- (A) The speed of sound determined from this experiment is 332 m s^{-1}
- (B) The end correction in this experiment is 0.9 cm
- (C) The wavelength of the sound wave is 66.4 cm
- (D) The resonance at 50.7 cm corresponds to the fundamental harmonic

Ans. [ABC or AC]

Sol. For $\left(p + \frac{1}{2}\right)$ half loops

$$\left(p + \frac{1}{2}\right) \frac{\lambda}{2} = l_1$$

$$\frac{(2p + 1)\lambda}{4} = l_1 = 50.7 \dots (1)$$

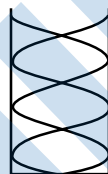

For $\left(p + \frac{3}{2}\right)$ half loops

$$\left(p + \frac{3}{2}\right) \frac{\lambda}{2} = l_2$$

$$\frac{(2p + 3)\lambda}{4} = l_2 = 83.9 \dots (2)$$

Solving (1) & (2) $\lambda = 66.4 \text{ cm}$

$$p = 1$$

$$f = \frac{v}{\lambda} \Rightarrow v = 500 \times \frac{66.4}{100} = 332 \text{ m/s}$$

So, option (A), (C)

SECTION 2

- This section contains EIGHT (08) questions. The answer to each question is a NUMERICAL VALUE.
- For each question, enter the correct numerical value (in decimal notation, truncated/rounded-off to the second decimal place; e.g. 6.25, 7.00, -0.33, -30, 30.27, -127.30) using the mouse and the on-screen virtual numeric keypad in the place designated to enter the answer.
- Answer to each question will be evaluated according to the following marking scheme:

Full Marks : +3 If ONLY the correct numerical value is entered as answer.

Zero Marks : 0 In all other cases.

7. A solid horizontal surface is covered with a thin layer of oil. A rectangular block of mass $m = 0.4 \text{ kg}$ is at rest on this surface. An impulse of 1.0 N s is applied to the block at time $t = 0$ so that it starts moving along the x -axis with a velocity $v(t) = v_0 e^{-t/\tau}$, where v_0 is a constant and $\tau = 4 \text{ s}$. The displacement of the block, in metres, at $t = \tau$ is _____. Take $e^{-1} = 0.37$.

Ans. [6.30]

Sol. $\frac{dx}{dt} = v_0 e^{-t/\tau}$

$$\int_0^x dx = \int_0^{\tau=4} v_0 e^{-t/\tau} dt$$

$$x = v_0 \tau (1 - e^{-1})$$

$$= v_0 \times 4 \times 0.63 \dots (1)$$

$$I = mv(0)$$

$$1 = 0.4 \times v_0$$

$$v_0 = 5/2$$

Put in (1)

$$x = \frac{5}{2} \times 4 \times 0.63 = 6.30$$

8. A ball is projected from the ground at an angle of 45° with the horizontal surface. It reaches a maximum height of 120 m and returns to the ground. Upon hitting the ground for the first time, it loses half of its kinetic energy. Immediately after the bounce, the velocity of the ball makes an angle of 30° with the horizontal surface. The maximum height it reaches after the bounce, in metres, is _____.

Ans. [30.00]

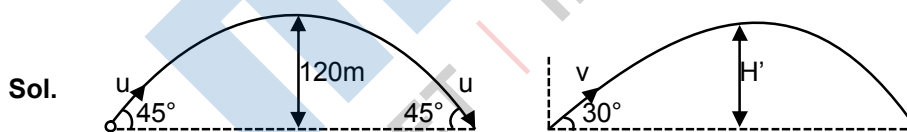

$$H' = \frac{v^2 \sin^2 30}{2g} \dots (1) ; \quad \frac{1}{2}mv^2 = \frac{1}{2} \times \frac{1}{2}mu^2$$

$$120 = \frac{u^2 \sin^2 45}{2g} \dots (2) ; \quad v = \frac{u}{\sqrt{2}}$$

From (1) & (2)
$$H' = 120 \times \left(\frac{v}{u}\right)^2 \left(\frac{1}{\frac{1}{\sqrt{2}}}\right)^2$$

$$H' = 30 \text{ m}$$

9. A particle, of mass 10^{-3} kg and charge 1.0 C, is initially at rest. At time $t = 0$, the particle comes under the influence of an electric field $\vec{E}(t) = E_0 \sin \omega t \hat{i}$, where $E_0 = 1.0 \text{ N C}^{-1}$ and $\omega = 10^3 \text{ rad s}^{-1}$. Consider the effect of only the electrical force on the particle. Then the maximum speed, in m s^{-1} , attained by the particle at subsequent times is _____.

Ans. [2.00]

Sol. $F = qE_0 \sin \omega t = m \frac{dv}{dt}$;

speed is maximum when $\frac{dv}{dt} = 0$

$\omega t = \pi \Rightarrow t = \pi/\omega$

$\frac{dv}{dt} = 0$

$v = \frac{2qE_0}{m\omega} = 2 \text{ m/s}$

10. A moving coil galvanometer has 50 turns and each turn has an area $2 \times 10^{-4} \text{ m}^2$. The magnetic field produced by the magnet inside the galvanometer is 0.02 T. The torsional constant of the suspension wire is $10^{-4} \text{ N m rad}^{-1}$. When a current flows through the galvanometer, a full scale deflection occurs if the coil rotates by 0.2 rad. The resistance of the coil of the galvanometer is 50Ω . This galvanometer is to be converted into an ammeter capable of measuring current in the range 0 – 1.0 A. For this purpose, a shunt resistance is to be added in parallel to the galvanometer. The value of this shunt resistance, in ohms, is _____.

Ans. [5.55]

Sol. $\tau = K\theta = NIAB$

$I_f = \frac{10^{-4} \times 0.2}{50 \times 2 \times 10^{-4} \times 0.02} \text{ A}$

$= 0.1 \text{ A}$

$0.1 \times 50 = 0.9 \times 5$

$S = 5.55 \Omega$

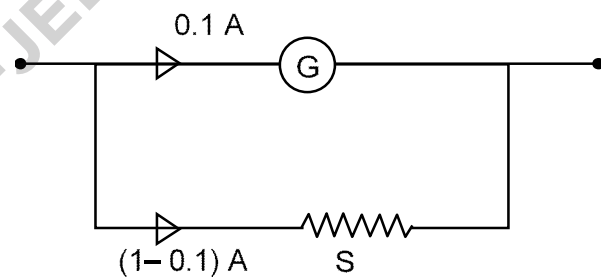

11. A steel wire of diameter 0.5 mm and Young's modulus $2 \times 10^{11} \text{ N m}^{-2}$ carries a load of mass M. The length of the wire with the load is 1.0 m. A vernier scale with 10 divisions is attached to the end of this wire. Next to the steel wire is a reference wire to which a main scale, of least count 1.0 mm, is attached. The 10 divisions of the vernier scale correspond to 9 divisions of the main scale. Initially, the zero of vernier scale coincides with the zero of main scale. If the load on the steel wire is increased by 1.2 kg, the vernier scale division which coincides with a main scale division is _____.

Take $g = 10 \text{ ms}^{-2}$ and $\pi = 3.2$.

Ans. [3.00]

Sol. $(\Delta m)g = \left(\frac{Ay}{l}\right)x$

$$x = \frac{1.2 \times 10 \times 1}{\frac{\pi}{4}(0.5 \times 10^{-3})^2 \times 2 \times 10^{11}} = 0.3 \text{ mm}$$

Since, least count of Vernier calliper is 0.1 m. So, third marking of Vernier scale coincides with a main scale division as $0.3 \text{ mm} = 0.1 \times 3 \text{ mm}$.

- 12.** One mole of a monatomic ideal gas undergoes an adiabatic expansion in which its volume becomes eight times its initial value. If the initial temperature of the gas is 100 K and the universal gas constant $R = 8.0 \text{ J mol}^{-1} \text{ K}^{-1}$, the decrease in its internal energy, in Joule, is _____.

Ans. [900.00]

Sol. $T.V^{\gamma-1} = \text{constant}, \gamma = \frac{5}{3}$

$$\frac{T_f}{T_i} = \left(\frac{1}{8}\right)^{\frac{5}{3}-1} \Rightarrow T_f = \frac{T_i}{4} = 25\text{K}$$

$$\Delta U = nC_v\Delta T = -1 \times \frac{3}{2} \times 8.0 \times 75 = -900 \text{ J}$$

- 13.** In a photoelectric experiment a parallel beam of monochromatic light with power of 200 W is incident on a perfectly absorbing cathode of work function 6.25 eV. The frequency of light is just above the threshold frequency so that the photoelectrons are emitted with negligible kinetic energy. Assume that the photoelectron emission efficiency is 100%. A potential difference of 500 V is applied between the cathode and the anode. All the emitted electrons are incident normally on the anode and are absorbed. The anode experiences a force $F = n \times 10^{-4} \text{ N}$ due to the impact of the electrons. The value of n is _____. Mass of the electron $m_e = 9 \times 10^{-31} \text{ kg}$ and $1.0 \text{ eV} = 1.6 \times 10^{-19} \text{ J}$.

Ans. [24.00]

Sol. If N are the number of photoelectrons, then

$$\frac{N}{t} \times 6.25 \times 1.6 \times 10^{-19} = 200$$

$$\frac{N}{t} = 2 \times 10^{20}$$

$$\frac{1}{2} \times m_e \times v_e^2 = |e| \times 500$$

$$v_e = \sqrt{\frac{1.6 \times 10^{-19} \times 500 \times 2}{9 \times 10^{-31}}} = \sqrt{1.8 \times 10^{14}} \text{ m/s}$$

$$F = \frac{N}{t} \times m_e v_e = 2 \times 10^{20} \times 9 \times 10^{-31} \times \sqrt{1.8 \times 10^{14}}$$

$$= 24 \times 10^{-4} \text{ J}$$

So, $n = 24.00$

14. Consider a hydrogen-like ionized atom with atomic number Z with a single electron. In the emission spectrum of this atom, the photon emitted in the $n = 2$ to $n = 1$ transition has energy 74.8 eV higher than the photon emitted in the $n = 3$ to $n = 2$ transition. The ionization energy of the hydrogen atom is 13.6 eV. The value of Z is _____.

Ans. [3.00]

Sol. $74.8 = 13.6 Z^2 \left[\left(1 - \frac{1}{2^2} \right) - \left(\frac{1}{2^2} - \frac{1}{3^2} \right) \right]$

$Z = 3$

SECTION 3

- This section contains FOUR (04) questions.
- Each question has TWO (02) matching lists: LIST-I and LIST-II.
- FOUR options are given representing matching of elements from LIST-I and LIST-II. ONLY ONE of these four options corresponds to a correct matching.
- For each question, choose the option corresponding to the correct matching.
- For each question, marks will be awarded according to the following marking scheme:

Full Marks : +3 If ONLY the option corresponding to the correct matching is chosen.

Zero Marks : 0 If none of the options is chosen (i.e. the question is unanswered).

Negative Marks : -1 In all other cases.

15. The electric field E is measured at a point $P(0, 0, d)$ generated due to various charge distributions and the dependence of E on d is found to be different for different charge distributions. List-I contains different relations between E and d . List-II describes different electric charge distributions, along with their locations. Match the functions in List-I with the related charge distributions in List-II.

List-I	List-II
P. E is independent of d	1. A point charge Q at the origin
Q. $E \propto \frac{1}{d}$	2. A small dipole with point charges Q at $(0, 0, l)$ and $-Q$ at $(0, 0, -l)$. Take $2l \ll d$
R. $E \propto \frac{1}{d^2}$	3. An infinite line charge coincident with the x -axis,
S. $E \propto \frac{1}{d^3}$	4. Two infinite wires carrying uniform linear charge $(y = 0, z = l)$ has a charge density $+\lambda$ and the
	5. Infinite plane charge coincident with the xy -plane with uniform surface charge density
(A) $P \rightarrow 5; Q \rightarrow 3, 4; R \rightarrow 1; S \rightarrow 2$	(B) $P \rightarrow 5; Q \rightarrow 3; R \rightarrow 1, 4; S \rightarrow 2$
(C) $P \rightarrow 5; Q \rightarrow 3; R \rightarrow 1, 2; S \rightarrow 4$	(D) $P \rightarrow 4; Q \rightarrow 2, 3; R \rightarrow 1; S \rightarrow 5$

Ans. [B]

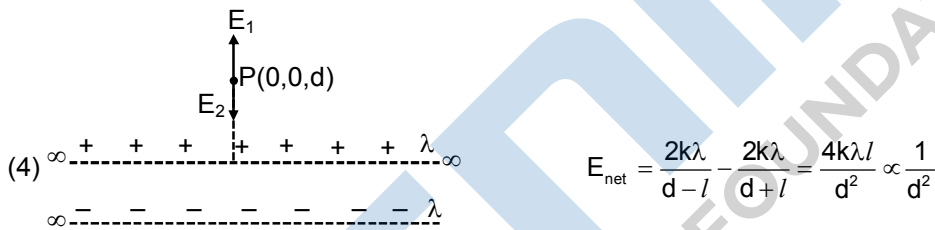
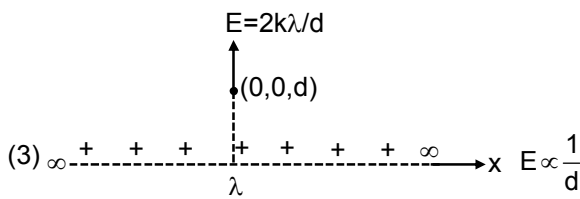
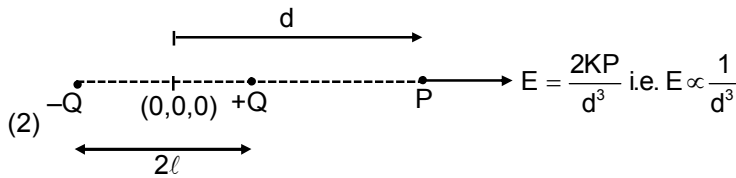
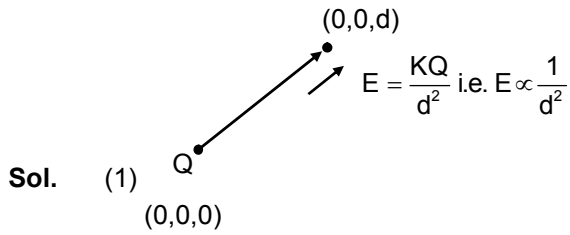

(P) → 5 ; (Q) → 3 ; (R) → 1, 4 ; (S) → 2
So option (B)

16. A planet of mass M , has two natural satellites with masses m_1 and m_2 . The radii of their circular orbits are R_1 and R_2 respectively. Ignore the gravitational force between the satellites. Define v_1 , L_1 , K_1 and T_1 to be, respectively, the orbital speed, angular momentum, kinetic energy and time period of revolution of satellite 1; and v_2 , L_2 , K_2 and T_2 to be the corresponding quantities of satellite 2.

Given $m_1 / m_2 = 2$ and $R_1 / R_2 = 1/4$, match the ratios in List-I to the numbers in List-II.

P. $\frac{v_1}{v_2}$ 1. $\frac{1}{8}$

Q. $\frac{L_1}{L_2}$ 2. 1

R. $\frac{K_1}{K_2}$

3. 2

S. $\frac{T_1}{T_2}$

4. 8

(A) P → 4; Q → 2; R → 1; S → 3

(B) P → 3; Q → 2; R → 4; S → 1

(C) P → 2; Q → 3; R → 1; S → 4

(D) P → 2; Q → 3, 3; R → 4; S → 1

Ans. [B]

Sol. $\frac{GMm}{R^2} = \frac{mv^2}{R}$

$v = \sqrt{\frac{GM}{R}}$;

$L = mvR$

$L = \sqrt{GMm^2R}$;

$K = \frac{1}{2}mv^2 = \frac{GMm}{2R}$

$T = \frac{2\pi R}{v} = \frac{2\pi R^{3/2}}{\sqrt{GM}}$;

$\frac{v_1}{v_2} = \frac{\sqrt{GM/R_1}}{\sqrt{GM/R_2}} = 2$; $\frac{L_1}{L_2} = \frac{\sqrt{m_1^2 \cdot R_1}}{\sqrt{m_2^2 \cdot R_2}} = 1$

$\frac{K_1}{K_2} = \frac{m_1}{m_2} \cdot \frac{R_2}{R_1} = 2.4 = 8$; $\frac{T_1}{T_2} = \left(\frac{R_1}{R_2}\right)^{3/2} = \frac{1}{8}$

So, option (B)

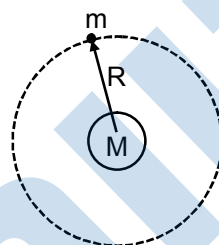

17. One mole of a monatomic ideal gas undergoes four thermodynamic processes as shown schematically in the PV-diagram below. Among these four processes, one is isobaric, one is isochoric, one is isothermal and one is adiabatic. Match the processes mentioned in List-1 with the corresponding statements in List-II.

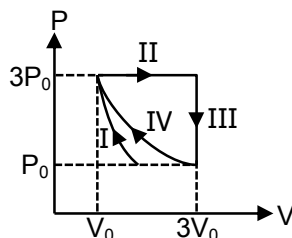

List-I

List-II

P. In process I

1. Work done by the gas is zero

In process II

2. Temperature of the gas remains unchanged

R. In process III
surroundings

S. In process IV

(A) $P \rightarrow 4; Q \rightarrow 3; R \rightarrow 1; S \rightarrow 2$

(C) $P \rightarrow 3; Q \rightarrow 4; R \rightarrow 1; S \rightarrow 2$

3. No heat is exchanged between the gas and its

4. Work done by the gas is $6P_0V_0$

(B) $P \rightarrow 1; Q \rightarrow 3; R \rightarrow 2; S \rightarrow 4$

(D) $P \rightarrow 3; Q \rightarrow 4; R \rightarrow 2; S \rightarrow 1$

Ans. [C]

Sol. Process I : Adiabatic as negative of slope is greater i.e. $\frac{dp}{dv} = -\frac{\gamma p}{v}$

Process IV : Isothermal process

Process III : Isochoric process

Process II : Isobaric process

Process I : No heat exchange

Process II : Work done = $P\Delta V$

$$= 3P_0(3V_0 - V_0)$$

$$= 6P_0V_0$$

Process III : Work done is zero as there is no volume change

Process IV : Since isothermal process i.e. temp. remains unchanged.

Option (C)

18. In the List-I below, four different paths of a particle are given as functions of time. In these functions, α and β are positive constants of appropriate dimensions and $\alpha \neq \beta$. In each case, the force acting on the particle is either zero or conservative. In List-II, five physical quantities of the particle are mentioned: \vec{p} is the linear momentum, \vec{L} is the angular momentum about the origin, K is the kinetic energy, U is the potential energy and E is the total energy. Match each path in List-I with those quantities in List-II, which are **conserved for that path**.

List-I

(P) $\vec{r}(t) = \alpha t \hat{i} + \beta t \hat{j}$

(Q) $\vec{r}(t) = \alpha \cos \omega t \hat{i} + \beta \sin \omega t \hat{j}$

(R) $\vec{r}(t) = \alpha(\cos \omega t \hat{i} + \sin \omega t \hat{j})$

(S) $\vec{r}(t) = \alpha t + \frac{\beta}{2} t^2 \hat{j}$

List-II

(1) \vec{p}

(2) \vec{L}

(3) K

(4) U

(5) E

(A) $P \rightarrow 1, 2, 3, 4, 5; Q \rightarrow 2, 5; R \rightarrow 2, 3, 4, 5; S \rightarrow 5$

(B) $P \rightarrow 1, 2, 3, 4, 5; Q \rightarrow 3, 5; R \rightarrow 2, 3, 4, 5; S \rightarrow 2, 5$

(C) $P \rightarrow 2, 3, 4; Q \rightarrow 5; R \rightarrow 1, 2, 4; S \rightarrow 2, 5$

(D) $P \rightarrow 1, 2, 3, 5; Q \rightarrow 2, 5; R \rightarrow 2, 3, 4, 5; S \rightarrow 2, 5$

Ans. [A]

Sol. (P) $\vec{r}(t) = \alpha t \hat{i} + \beta t \hat{j}$

$\vec{v}(t) = \alpha \hat{i} + \beta \hat{j}$ velocity is constant so \vec{p} and K is conserved

$\vec{a}(t) = 0$

$\vec{F} = 0$

$\vec{\tau} = \vec{r} \times \vec{F} = 0$ so \vec{L} is conserved

$dU = -\vec{F} \cdot d\vec{r} = 0$ so U is conserved and E is also conserved

(Q) $\vec{r}(t) = \alpha \cos \omega t \hat{i} + \beta \sin \omega t \hat{j}$

$\vec{v}(t) = -\alpha \omega \sin \omega t \hat{i} + \beta \omega \cos \omega t \hat{j}$

$\vec{a}(t) = -\omega^2 (\alpha \cos \omega t \hat{i} + \beta \sin \omega t \hat{j}) = -\omega^2 \vec{r}$

$\vec{F}(t) = -m\omega^2 \vec{r}$

$\vec{\tau} = \vec{r} \times \vec{F} = 0$ so L is conserved

$dU = -\vec{F} \cdot d\vec{r}$

$U = \frac{m\omega^2 r^2}{2} + \text{constant}$

$U + K = \text{constant}$

(R) As in Q if $\beta = \alpha$ speed becomes constant so K is conserved so U is also conserved as r is constant

(S) $\vec{r}(t) = \alpha t + \frac{\beta}{2} t^2 \hat{j}$ similar to projectile only E is conserved.

PART B: CHEMISTRY

SECTION 1

19. The correct option(s) regarding the complex $[\text{Co}(\text{en})(\text{NH}_3)_3(\text{H}_2\text{O})]^{3+}$ (en = $\text{H}_2\text{NCH}_2\text{CH}_2\text{NH}_2$) is (are)
- (A) It has two geometrical isomers
- (B) It will have three geometrical isomers if bidentate 'en' is replaced by two cyanide ligands
- (C) It is paramagnetic
- (D) It absorbs light at longer wavelength as compared to $[\text{Co}(\text{en})(\text{NH}_3)_4]^{3+}$

Ans. [A, B, D]

Sol. $[\text{Co}(\text{en})(\text{NH}_3)_3(\text{H}_2\text{O})]^{3+}$ (en = AA, $\text{NH}_3 = a$, $\text{H}_2\text{O} = b$)

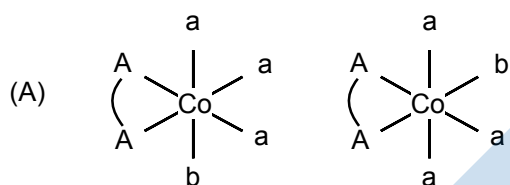

$$\text{G.I.} = 2, \text{O.I.} = 0, \text{Total} = 2$$

(B) $\text{A} \curvearrowright \text{A} \Rightarrow 2c$ (two CN^-), G.I. = 3

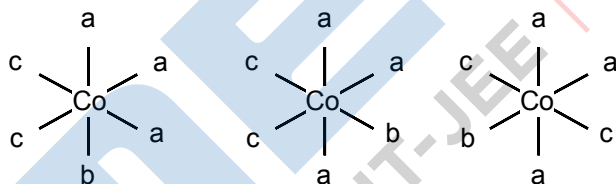

(C) $\text{Co}^{3+} : d^6$, SFL, Dia

(D) $\text{CFSE} \rightarrow [\text{Co}(\text{en})(\text{NH}_3)_4]^{3+} > [\text{Co}(\text{en})(\text{NH}_3)_3(\text{H}_2\text{O})]^{3+}$

$$\text{CFSE} \propto E_{\text{absorb}} = \frac{hc}{\lambda_{\text{absorb}}}$$

$$\lambda_{\text{absorb}} \text{ of } [\text{Co}(\text{en})(\text{NH}_3)_4]^{3+} < [\text{Co}(\text{en})(\text{NH}_3)_3\text{H}_2\text{O}]^{3+}$$

20. The correct option(s) to distinguish nitrate salts of Mn^{2+} and Cu^{2+} taken separately is (are)
- (A) Mn^{2+} shows the characteristic green colour in the flame test
- (B) Only Cu^{2+} shows the formation of precipitate by passing H_2S in acidic medium
- (C) Only Mn^{2+} shows the formation of precipitate by passing H_2S in faintly basic medium
- (D) Cu^{2+}/Cu has higher reduction potential than Mn^{2+}/Mn (measured under similar conditions)

Ans. [B, D]

- Sol. (A) Mn^{2+} does not give colour in flame test
 (B) Cu^{2+} group II cation is precipitate ($H_2S + dil.HCl$) while Mn^{2+} does not precipitate
 (C) Mn^{2+} and Cu^{2+} both are precipitate in ($H_2S + OH^-$)
 (D) $E_{Cu^{2+}/Cu} > E_{Mn^{2+}/Mn}$

21. Aniline reacts with mixed acid (conc. HNO_3 and conc. H_2SO_4) at 288 K to give **P** (51 %), **Q** (47%) and **R** (2%). The major product(s) of the following reaction sequence is (are)

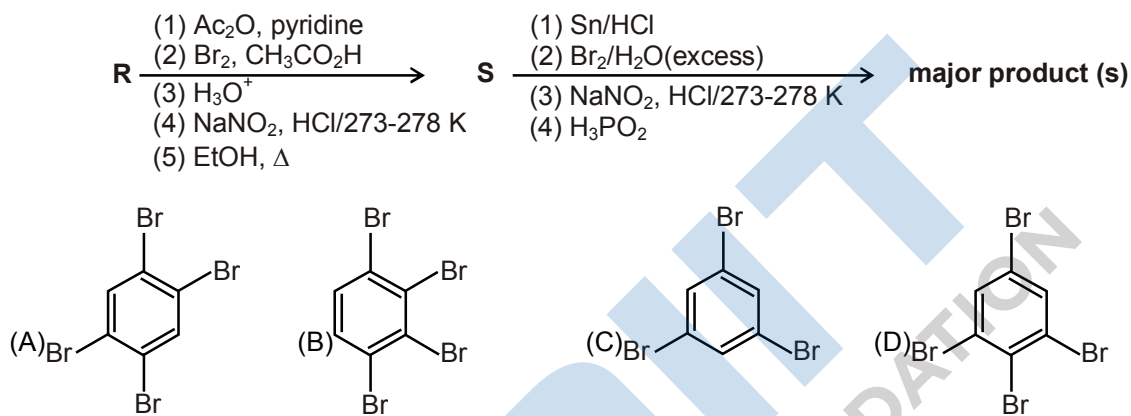

Ans. [D]

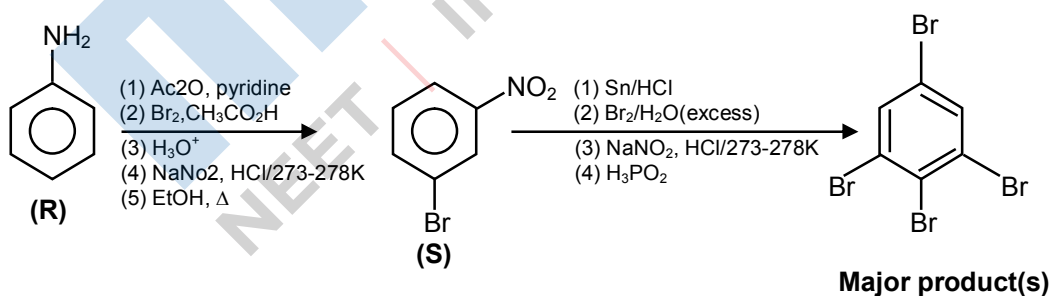
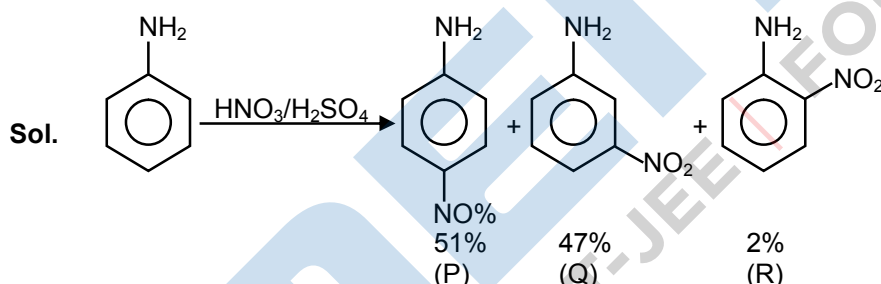

22. The Fischer presentation of D-glucose is given below.

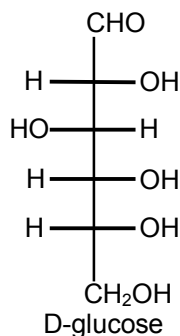

The correct structure(s) of β -L-glucopyranose is (are)

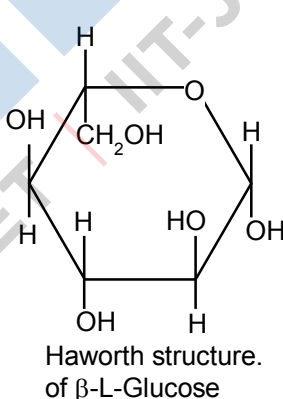
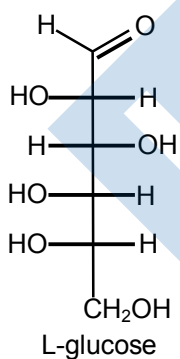
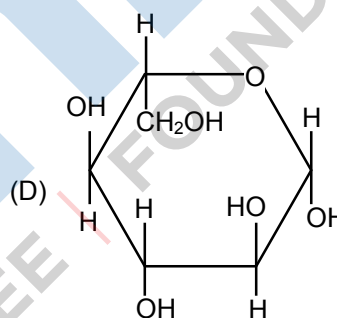
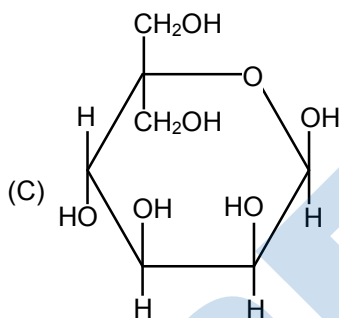
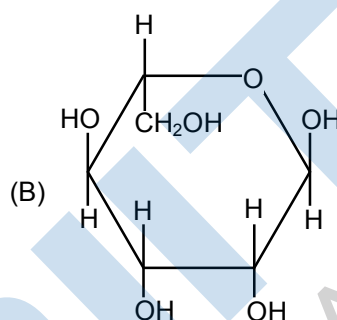
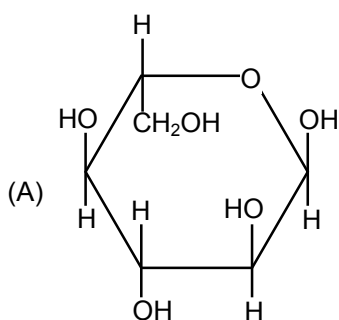

23. For a first order reaction $A(g) \rightarrow 2B(g) + C(g)$ at constant volume and 300 K, the total pressure at the beginning ($t = 0$) and at time t are P_0 and P_t , respectively. Initially, only A is present with concentration $[A]_0$, and $t_{1/3}$ is the time required for the partial pressure of A to reach $1/3^{\text{rd}}$ of its initial value. The correct option(s) is (are) (Assume that all these gases behave as ideal gases)

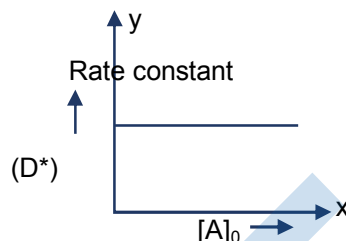
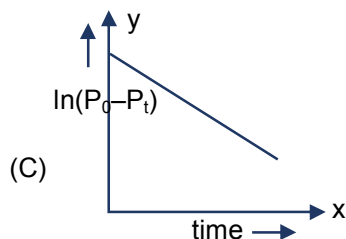
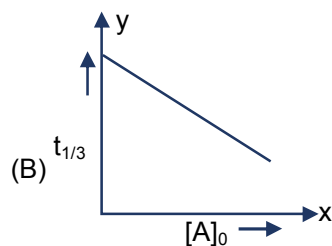
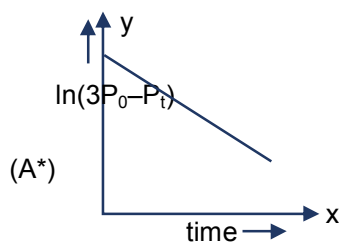

Ans. [A,D]

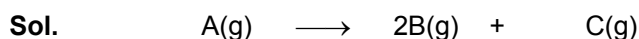

$t = 0$ P_0 0 0

$t = t$ $P_0 - P$ $2P$ P $P_t = P_0 + 2P$

$$Kt = \ln \frac{P_0}{P_0 - \left(\frac{P_t - P_0}{2}\right)} = \ln \frac{2P_0}{3P_0 - P_t} = \ln 2P_0 - \ln(3P_0 - P_t)$$

$$\ln(3P_0 - P_t) = -Kt + \ln 2P_0$$

$$Kt_{1/3} = \ln \frac{1}{1/3} = \ln 3$$

$$t_{1/3} = \frac{\ln 3}{K} \Rightarrow t_{1/3} \text{ is independent of initial concentration}$$

24. For a reaction, $A \rightleftharpoons P$, the plots of $[A]$ and $[P]$ with time at temperatures T_1 and T_2 are given below.

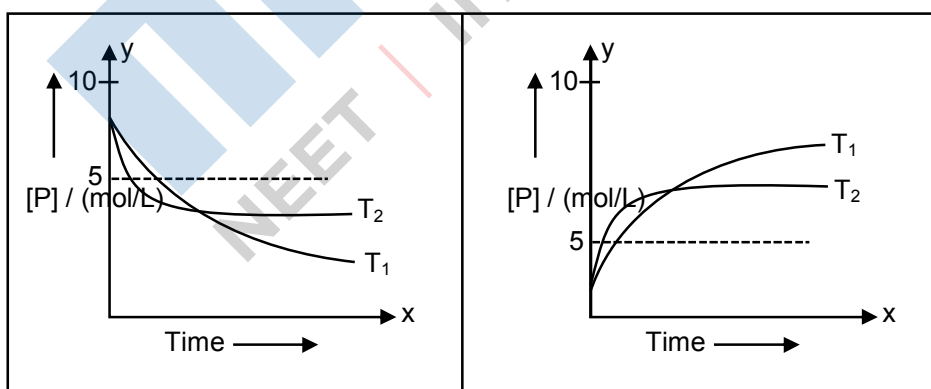

If $T_2 > T_1$, the correct statement(s) is (are)

(Assume ΔH^θ and ΔS^θ are independent of temperature and ratio of $\ln K$ at T_1 to $\ln K$ at T_2 is greater than T_2/T_1 . Here H, S, G and K are enthalpy, entropy, Gibbs energy and equilibrium constant, respectively.)

(A) $\Delta H^\theta < 0, \Delta S^\theta < 0$

(B) $\Delta G^\theta < 0, \Delta H^\theta > 0$

(C) $\Delta G^\circ < 0, \Delta S^\circ < 0$

(D) $\Delta G^\circ < 0, \Delta S^\circ > 0$

Ans. [A,C]

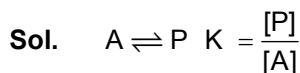

On increasing temperature $[A]_2 > [A]_1$ and $[P]_2 < [P]_1$, it means value of equilibrium constant decreases.

So process is exothermic. ($\Delta H < 0$)

$$\Delta G^\circ = -RT \ln K$$

Clearly $K > 1 \Rightarrow \Delta G^\circ < 0$

[From graphs $[P]_{eq} > [A]_{eq}$]

$$\frac{\ln K_{T_1}}{\ln K_{T_2}} > \frac{T_2}{T_1} \text{ and } \frac{T_2}{T_1} > 1$$

$$\ln K_{T_1} > \ln K_{T_2}$$

$$-RT_2 \ln K_{T_2} > -RT_1 \ln K_{T_1}$$

$$\therefore \Delta G_2^\circ > \Delta G_1^\circ$$

$$\Rightarrow \Delta H^\circ - T_2 \Delta S^\circ > \Delta H^\circ - T_1 \Delta S^\circ \Rightarrow -T_2 \Delta S^\circ > -T_1 \Delta S^\circ \quad T_2 > T_1 \therefore \Delta S < 0$$

SECTION 2

25. The total number of compounds having at least one bridging oxo group among the molecules given below is ____.



Ans. [6]

Sol. (i) N_2O_3

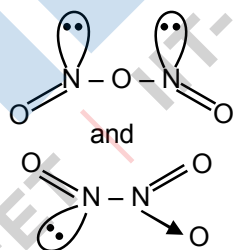

(ii) N_2O_5

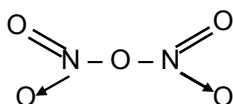

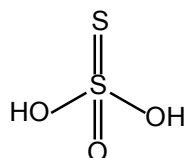
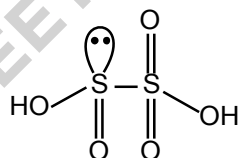
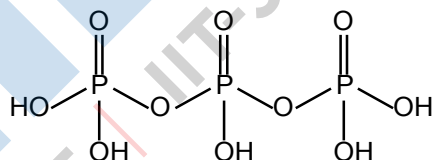
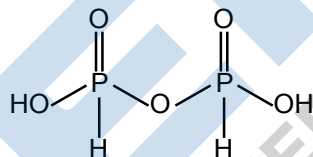
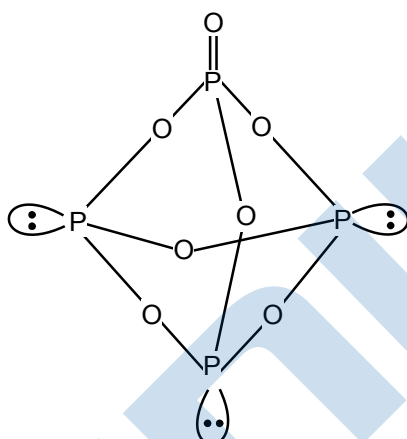
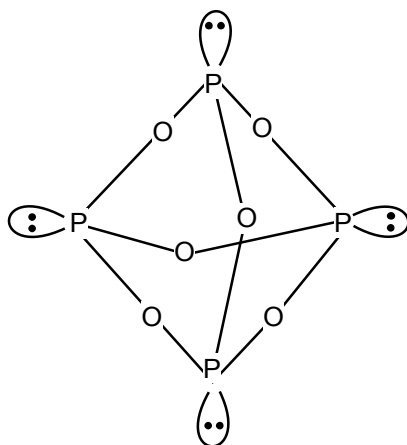

26. Galena (an ore) is partially oxidized by passing air through it at high temperature. After some time, the passage of air is stopped, but the heating is continued in a closed furnace such that the contents undergo self-reduction. The weight (in kg) of Pb produced per kg of O_2 consumed is _____.

(Atomic weights in g mol^{-1} : O = 16, S = 32, Pb = 207)

Ans. [6.47]

Sol. Reaction involved : $\text{PbS} + \frac{3}{2}\text{O}_2 \xrightarrow{\Delta} \text{PbO} + \text{SO}_2$ (Partial roasting)

(Galena)

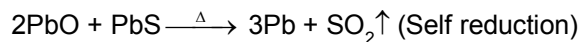

$$\text{Number of moles of 1 kg of oxygen gas } (n_{\text{O}_2}) = \frac{1000}{32}$$

$$\text{Number of moles of Pb produced } (n_{\text{Pb}}) = \frac{1000}{32} \times \frac{2}{3} \times \frac{3}{2}$$

$$\text{Weight of Pb produced } (W_{\text{Pb}}) = \frac{1000}{32} \times \frac{2}{3} \times \frac{3}{2} \times 207 = 6468.75 \text{ gm} \approx 6.47 \text{ kg}$$

27. To measure the quantity of MnCl_2 dissolved in an aqueous solution, it was completely converted to KMnO_4 using the reaction,

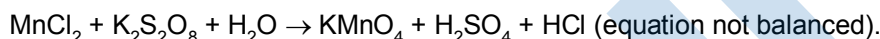

Few drops of concentrated HCl were added to this solution and gently warmed. Further, oxalic acid (225 mg) was added in portions till the colour of the permanganate ion disappeared. The quantity of MnCl_2 (in mg) present in the initial solution is _____.

(Atomic weights in g mol^{-1} : Mn = 55, Cl = 35.5)

Ans. [126]

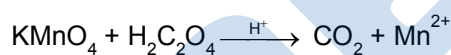
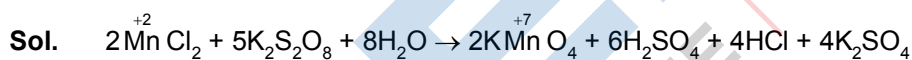

$$n_f = 5 \qquad n_f = 2$$

$$\text{mm of H}_2\text{C}_2\text{O}_4 = \frac{225}{90} = 2.5$$

$$m_{\text{eq}} \text{ of KMnO}_4 = m_{\text{eq}} \text{ of H}_2\text{C}_2\text{O}_4$$

$$5 \times \text{mmol of KMnO}_4 = 2 \times 2.5$$

$$\text{mmol of KMnO}_4 = 1$$

$$\text{mmol of MnCl}_2 = 1$$

$$\text{mass of MnCl}_2 = (55 + 71) \text{ mg} = 126 \text{ mg}$$

28. For the given compound X, the total number of optically active stereoisomers is

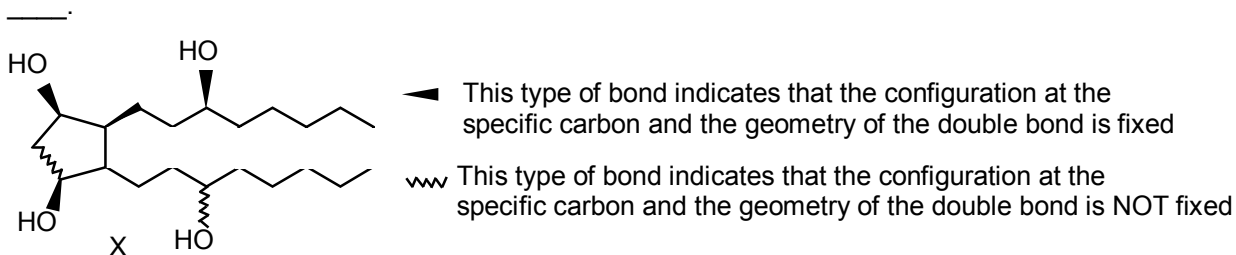

Ans. [7]

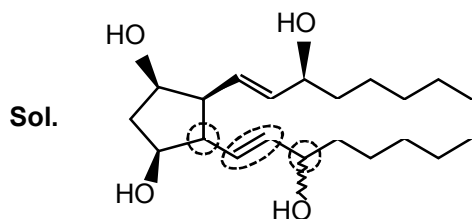

Stereoisomerism can be about circle system as other systems are fixed total $2^3 = 8$ stereoisomers with 7 optically active.

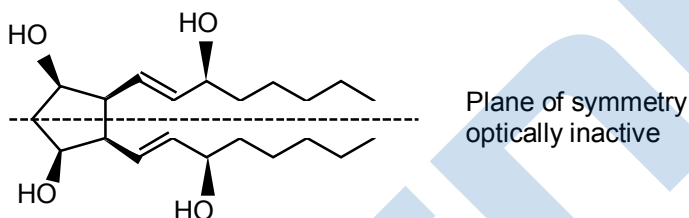

29. In the following reaction sequence, the amount of D (in g) formed from 10 moles of acetophenone is

_____.

(Atomic weights in g mol^{-1} : H = 1, C = 12, N = 14, O = 16, Br = 80. The yield (%) corresponding to the product in each step is given in the parenthesis)

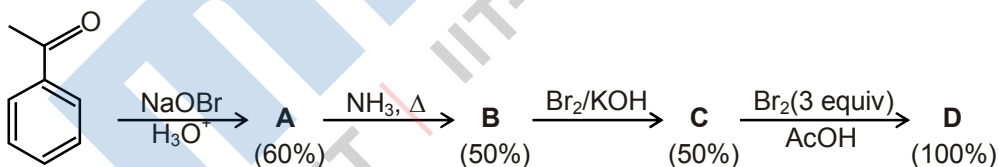

Ans. [495]

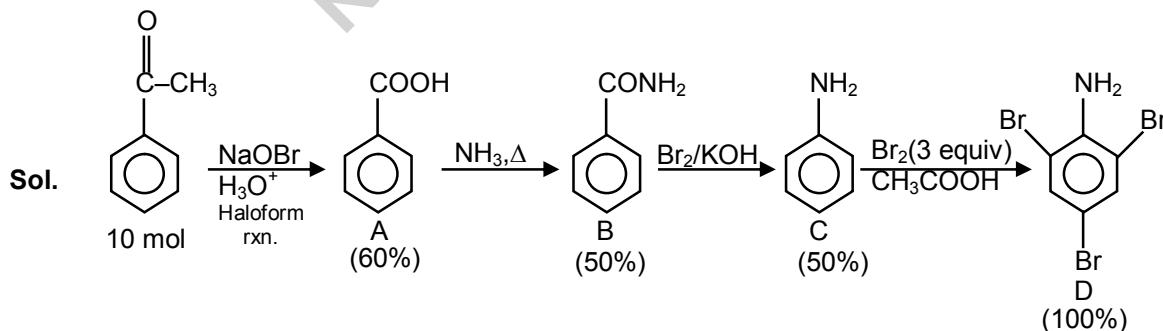

Moles of D = $10 \times 0.6 \times 0.5 \times 0.5 = 1.5$

Molar mass of D = 330

∴ Mass of D will be $1.5 \times 330 = 495$ g

30. The surface of copper gets tarnished by the formation of copper oxide. N_2 gas was passed to prevent the oxide formation during heating of copper at 1250 K. However, the N_2 gas contains 1 mole % of water vapour as impurity. The water vapour oxidises copper as per the reaction given below:

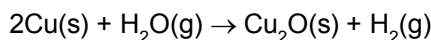

p_{H_2} is the minimum partial pressure of H_2 (in bar) needed to prevent the oxidation at 1250 K.

The value of $\ln(p_{H_2})$ is _____.

(Given: total pressure = 1 bar, R (universal gas constant) = $8 \text{ J K}^{-1} \text{ mol}^{-1}$, $\ln(10) = 2.3$. $Cu(s)$ and $Cu_2O(s)$ are mutually immiscible.

At 1250 K: $2Cu(s) + \frac{1}{2} O_2(g) \rightarrow Cu_2O(s)$; $\Delta G^\ominus = -78,000 \text{ J mol}^{-1}$

$H_2(g) + \frac{1}{2} O_2(g) \rightarrow H_2O(g)$; $\Delta G^\ominus = -1,78,000 \text{ J mol}^{-1}$; G is the Gibbs energy)

Ans. [- 14.6]

Sol. $2Cu(s) + 1/2O_2(g) \rightarrow Cu_2O(s)$ $\Delta G^\ominus = -78000 \text{ J/mol}$ (i)

$H_2(g) + 1/2O_2(g) \rightarrow H_2O(g)$ $\Delta G^\ominus = -1,78,000 \text{ J/mol}$ (ii)

(i) - (ii)

$2Cu(s) + H_2O(g) \rightarrow Cu_2O(s) + H_2(g)$ $\Delta G^\ominus = 10^5 \text{ J/mol}$

$$\Delta G = \Delta G^\ominus + RT \ln \frac{P_{H_2}}{P_{H_2O}}$$

To prevent the oxidation

$$\Delta G \geq 0 \Rightarrow \Delta G^\ominus + RT \ln \frac{P_{H_2}}{P_{H_2O}} \geq 0$$

$$8 \times 1250(\ln P_{H_2} - \ln P_{H_2O}) \geq -10^5$$

$$\ln P_{H_2} - \ln P_{H_2O} \geq -10$$

$$\ln P_{H_2} \geq -10 + \ln P_{H_2O}$$

Total pressure is 1 bar and 1% water vapors are present ∴ $\ln P_{H_2O} = \ln 0.01$

$$\ln P_{H_2} \geq -10 + 2.3 \ln 10^{-2}$$

$$\ln P_{H_2} \geq -10 - 4.6$$

$$\ln P_{H_2} \geq -14.6$$

31. Consider the following reversible reaction,

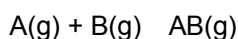

The activation energy of the backward reaction exceeds that of the forward reaction by $2RT$ (in J mol^{-1}). If the pre-exponential factor of the forward reaction is 4 times that of the reverse reaction, the absolute value of ΔG^\ominus (in J mol^{-1}) for the reaction at 300 K is ____.

(Given; $\ln(2) = 0.7$, $RT = 2500 \text{ J mol}^{-1}$ at 300 K and G is the Gibbs energy)

Ans. [8500]

Sol. $A(g) + B(g) \rightleftharpoons AB(g)$

$$\Delta G^\ominus = -RT \ln K$$

$$K = \frac{K_f}{K_b} = \frac{A_f e^{-E_{af}/RT}}{A_b e^{-E_{ab}/RT}} = 4e^{-(E_{af}-E_{ab})/RT}$$

$$K = 4 e^{+2RT/RT} = 4e^2$$

$$|\Delta G^\ominus| = 2500 \ln 4e^2 = 2500 (\ln 4 + \ln e^2)$$

$$|\Delta G^\ominus| = 2500 (2 \ln 2 + 2) = 2500 (1.4 + 2)$$

$$= 2500 \times 3.4 = 8500$$

32. Consider an electrochemical cell: $A(s) | A^{n+}(\text{aq}, 2 \text{ M}) || B^{2n+}(\text{aq}, 1 \text{ M}) | B(s)$. The value of ΔH^\ominus for the cell reaction is twice that of ΔG^\ominus at 300 K. If the emf of the cell is zero, the ΔS^\ominus (in $\text{J K}^{-1} \text{ mol}^{-1}$) of the cell reaction per mole of B formed at 300 K is ____.

(Given: $\ln(2) = 0.7$, R (universal gas constant) = $8.3 \text{ J K}^{-1} \text{ mol}^{-1}$. H, S and G are enthalpy, entropy and Gibbs energy, respectively.)

Ans. [- 11.62]

Sol. $A(s) \longrightarrow A^{n+}(\text{aq}, 2\text{M}) + ne^- \times 2$

$2ne^- + B^{2n+}(\text{aq}, 1\text{M}) \longrightarrow B(s)$

$2A(s) + B^{2n+}(\text{aq}, 1\text{M}) \longrightarrow B(s) + 2A^{n+}(\text{aq}, 2\text{M})$

$$\Delta G^\ominus = \Delta H^\ominus - T\Delta S^\ominus$$

$$\Delta G^\ominus = 2\Delta G^\ominus - T\Delta S^\ominus$$

$$T\Delta S^\ominus = \Delta G^\ominus$$

$$\Delta G^\ominus = -nFE^\ominus = -RT \ln K$$

$$\Delta G^\ominus = -RT \ln \frac{4}{1}$$

$$\Delta G^\ominus = -2RT \times 0.7 = -1.4 RT$$

$$\Rightarrow T\Delta S^\ominus = -1.4 RT$$

$$\therefore \Delta S^\ominus = -1.4 \times R = -1.4 \times 8.3 \text{ J mol}^{-1} \text{ K}^{-1}$$

$$= -11.62 \text{ J mol}^{-1} \text{ K}^{-1}$$

SECTION 3

33. Match each set of hybrid orbitals from LIST-I with complex(es) given in LIST-II.

LIST-I		LIST-II	
P.	dsp^2	1.	$[\text{FeF}_6]^{4-}$
Q.	sp^3	2.	$[\text{Ti}(\text{H}_2\text{O})_3\text{Cl}_3]$
R.	sp^3d^2	3.	$[\text{Cr}(\text{NH}_3)_6]^{3+}$
S.	d^2sp^3	4.	$[\text{FeCl}_4]^{2-}$
		5.	$\text{Ni}(\text{CO})_4$
		6.	$[\text{Ni}(\text{CN})_4]^{2-}$

The correct option is

- (A) P → 5; Q → 4,6; R → 2,3; S → 1
 (B) P → 5,6; Q → 4; R → 3; S → 1, 2
 (C) P → 6; Q → 4,5; R → 1; S → 2, 3
 (D) P → 4,6; Q → 5,6; R → 1,2; S → 3

Ans. [C]

Sol.	(1)	$[\text{FeF}_6]^{4-}$	Fe^{2+} , WFL	–	sp^3d^2
	(2)	$[\text{Ti}(\text{H}_2\text{O})_3\text{Cl}_3]$	Ti^{+3} , WFL	–	d^2sp^3
	(3)	$[\text{Cr}(\text{NH}_3)_6]^{3+}$	Cr^{+3} , SFL	–	d^2sp^3
	(4)	$[\text{FeCl}_4]^{2-}$	Fe^{2+} , d^6 , WFL	–	sp^3
	(5)	$\text{Ni}(\text{CO})_4$	Ni^0 , d^{10} , SFL	–	sp^3
	(6)	$[\text{Ni}(\text{CN})_4]^{2-}$	Ni^{2+} , d^8 , SFL	–	dsp^2

34. The desired product X can be prepared by reacting the major product of the reactions in LIST-I with one or more appropriate reagents in LIST-II.

(given, order of migratory aptitude: aryl > alkyl > hydrogen)

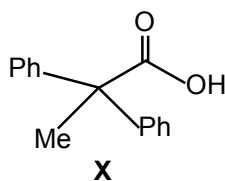

LIST-I

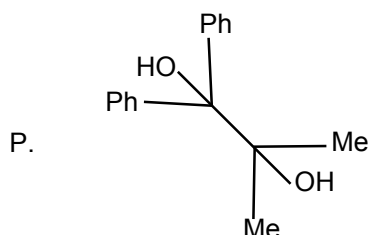

LIST-II

1. I_2, NaOH

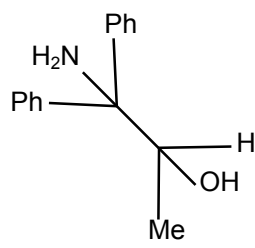
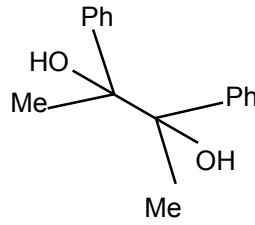
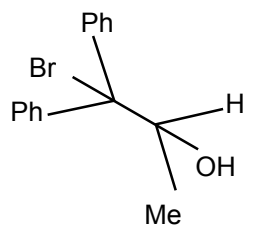
- Q.  + HNO₂ 2. [Ag(NH₃)₂]OH
- R.  + H₂SO₄ 3. Fehling solution
- S.  + AgNO₃ 4. HCHO, NaOH
5. NaOBr

The Correct options is

- (A) P → 1; Q → 2,3; R → 1, 4; S → 2,4 (B) P → 1,5; Q → 3, 4; R → 4, 5; S → 3
(C) P → 1,5; Q → 3,4; R → 5; S → 2, 4 (D) P → 1,5; Q → 2,3; R → 1, 5; S → 2,3

Ans. [D]

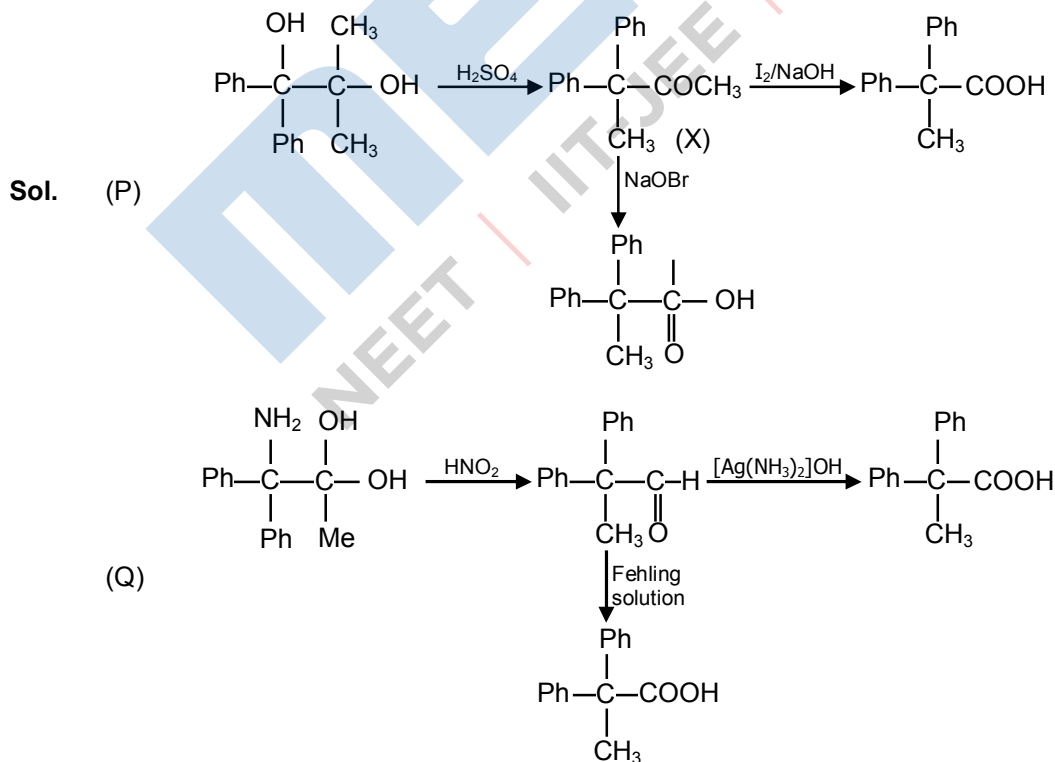

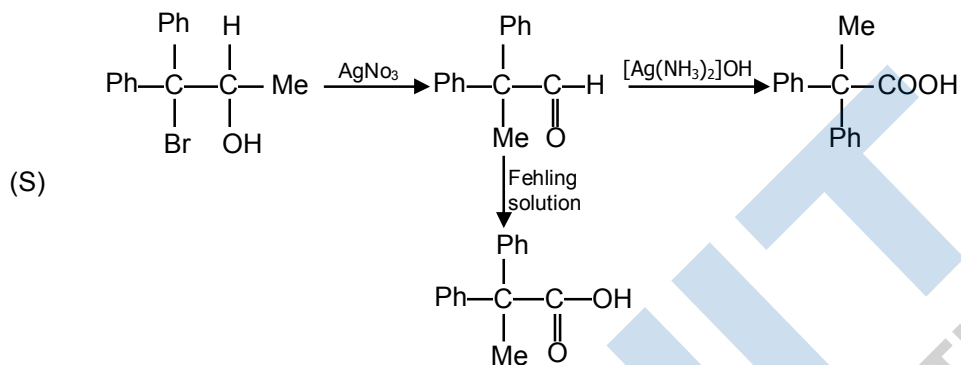
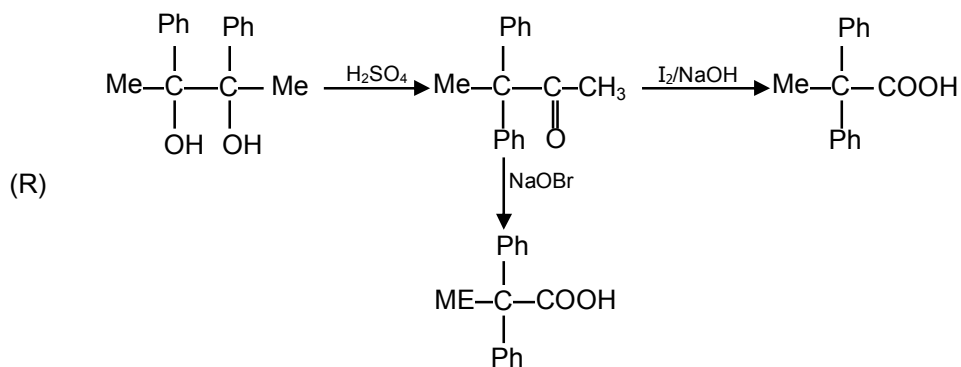

35. LIST-I contains reactions and LIST-II contains major products.

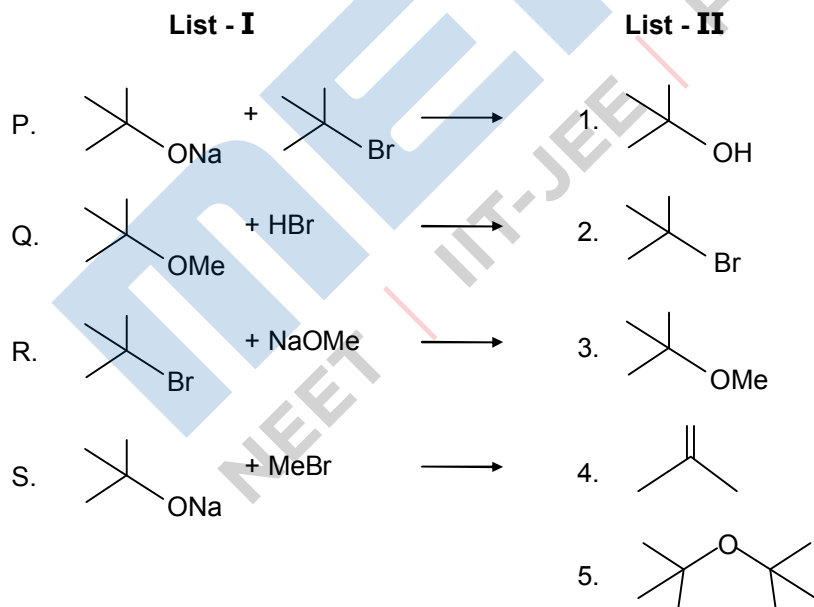

Match each reaction in LIST-I with one or more products in LIST-II and choose the correct option.

(A) P → 1,5; Q → 2; R → 3; S → 4

(B) P → 1,4; Q → 2; R → 4; S → 3

(C) P → 1,4; Q → 1,2; R → 3,4; S → 4

(D) P → 4,5; Q → 4; R → 4; S → 3,4

Ans. [B]

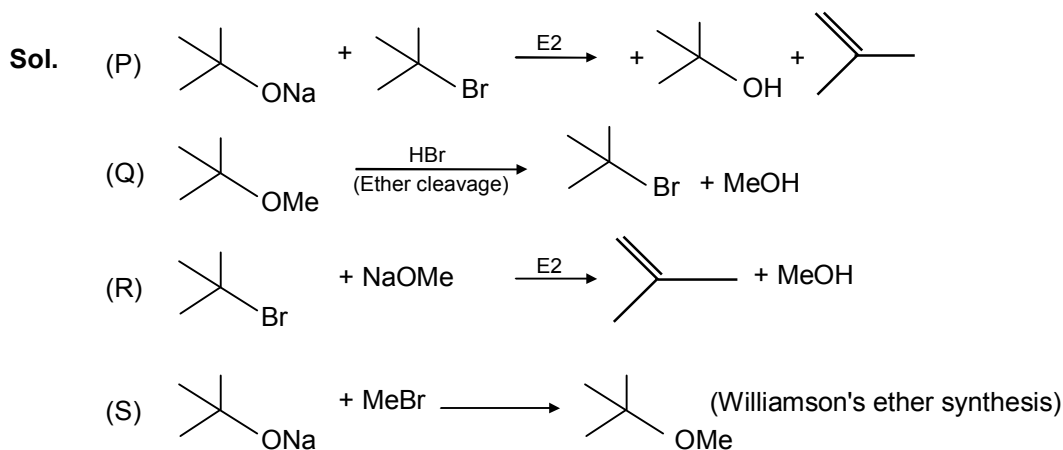

36. Dilution processes of different aqueous solutions, with water, are given in LIST-I. The effects of dilution of the solutions on $[H^+]$ are given in LIST-II.

(Note: Degree of dissociation (α) of weak acid and weak base is $\ll 1$; degree of hydrolysis of salt $\ll 1$; $[H^+]$ represents the concentration of H^+ ions)

LIST-I

- P. (10 mL of 0.1 M NaOH + 20 mL of 0.1 M acetic acid) diluted to 60 mL
- Q. (20 mL of 0.1 M NaOH + 20 mL of 0.1 M acetic acid) diluted to 80 mL
- R. (20 mL of 0.1 M HCl + 20 mL of 0.1 M ammonia solution) diluted to 80 mL
- S. 10 mL saturated solution of $Ni(OH)_2$ in equilibrium with excess solid $Ni(OH)_2$ is diluted to 20 mL (solid $Ni(OH)_2$ is still present after dilution).

LIST-II

1. the value of $[H^+]$ does not change on dilution
2. the value of $[H^+]$ changes to half of its initial value on dilution
3. the value of $[H^+]$ changes to two times of its initial value on dilution
4. the value of $[H^+]$ changes to $\frac{1}{\sqrt{2}}$ times of its initial value on dilution
5. the value of $[H^+]$ changes to $\sqrt{2}$ times of its initial value on dilution

Match each process given in LIST-I with one or more effect(s) in LIST-II. The correct option is

- (A) P \rightarrow 4; Q \rightarrow 2; R \rightarrow 3; S \rightarrow 1 (B) P \rightarrow 4; Q \rightarrow 3; R \rightarrow 2; S \rightarrow 3
- (C) P \rightarrow 1; Q \rightarrow 4; R \rightarrow 5; S \rightarrow 3 (D) P \rightarrow 1; Q \rightarrow 5; R \rightarrow 4; S \rightarrow 1

Ans. [D]

Sol.

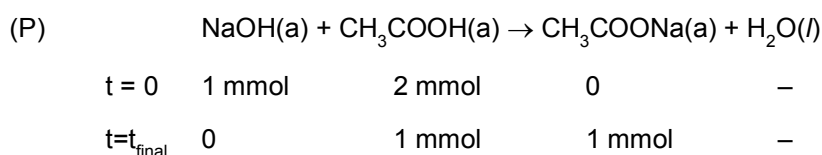

Due to presence of equal moles of CH_3COOH and CH_3COONa the solution becomes buffer solution.

$$\therefore \text{pH}_i = \text{pK}_a + \log \frac{1/30}{1/30} \quad (\text{Initial volume of solution} = 30 \text{ mL})$$

$$\text{i.e. } \text{pH}_i = \text{pK}_a$$

$$\text{Also, } \text{pH}_f = \text{pK}_a + \log \frac{1/60}{1/60} \Rightarrow \text{pH}_f = \text{pK}_a$$

$$\therefore \text{pH}_i = \text{pH}_f \quad \text{i.e. value of } [\text{H}^+] \text{ does not change on dilution.}$$

$$\therefore (\text{P}) \rightarrow (1)$$



$t = 0$	2 mmol	2 mmol	0	–
$t = t_{\text{final}}$	0	0	2 mmol	–

$$\therefore [\text{CH}_3\text{COONa}]_i = \frac{2}{40} \text{ M} = c \quad (\text{say})$$

$$\therefore [\text{H}^+]_i = \sqrt{\frac{K_w \cdot K_a}{c}}$$

$$\text{Finally, } [\text{CH}_3\text{COONa}]_f = \frac{2}{80} \text{ m} = \frac{c}{2}$$

$$\therefore [\text{H}^+]_f = \sqrt{\frac{K_w \cdot K_a}{c/2}} = \sqrt{2} [\text{H}^+]_i$$

$$\therefore (\text{Q}) \rightarrow (5)$$



$$\text{But, } [\text{H}^+] = \sqrt{\frac{K_w \cdot c}{K_b}}$$

$$\text{and } [\text{NH}_4\text{Cl}]_i = \frac{2}{40} \text{ M} = c' \quad (\text{say})$$

$$\therefore [\text{H}^+]_i = \sqrt{\frac{K_w \cdot c'}{K_b}}$$

$$\text{Also, } [\text{NH}_4\text{Cl}]_f = \frac{2}{80} \text{ M} = \frac{c'}{2}$$

$$\therefore \therefore [\text{H}^+]_f = \sqrt{\frac{K_w \cdot c'}{2K_b}} = \frac{[\text{H}^+]_i}{\sqrt{2}}$$

$$\therefore (\text{R}) \rightarrow (4)$$

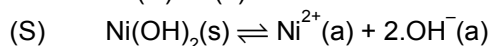

After dilution also, solution will remain saturated as dissociated and undissociated form will be in equilibrium.

$$\therefore [\text{OH}^-] \text{ does not change after dilution.}$$

$$\therefore [\text{H}^+] \text{ does not change after dilution.}$$

$$\therefore (\text{S}) \rightarrow (1)$$

PART C: MATHEMATICS

SECTION 1

37. For any positive integer n , define $f_n : (0, \infty) \rightarrow \mathbf{R}$ as

$$f_n(x) = \sum_{j=1}^n \tan^{-1} \left(\frac{1}{1+(x+j)(x+j-1)} \right) \text{ for all } x \in (0, \infty).$$

(Here, the inverse trigonometric function $\tan^{-1} x$ assumes values in $[-\frac{\pi}{2}, \frac{\pi}{2}]$.)

Then, which of the following statement(s) is(are) TRUE ?

(A) $\sum_{j=1}^5 \tan^2(f_j(0)) = 55$

(B) $\sum_{j=1}^{10} (1 + f_j'(0)) \sec^2(f_j(0)) = 10$

(C) For any fixed positive integer n , $\lim_{x \rightarrow \infty} \tan(f_n(x)) = \frac{1}{n}$

(D) For any fixed positive integer n , $\lim_{x \rightarrow \infty} \sec^2(f_n(x)) = 1$

Ans. [D]

Sol. $f_n(x) = \sum_{j=1}^n \tan^{-1}((x+j)) - \tan^{-1}(x+j-1) = \tan^{-1}(x+n) - \tan^{-1}(x) = \tan^{-1} \left(\frac{n}{1+x^2+nx} \right)$

(A) $x = 0$ is not in domain

(B) $x = 0$ is not in domain

(C) $\lim_{x \rightarrow \infty} \frac{n}{1+x^2+nx} = 0$

(D) $\lim_{x \rightarrow \infty} 1 + \left(\frac{n}{1+x^2+nx} \right)^2 = 1$

38. Let T be the line passing through the points $P(-2, 7)$ and $Q(2, -5)$. Let F_1 be the set of all pairs of circles (S_1, S_2) such that T is tangent to S_1 at P and tangent to S_2 at Q and also such that S_1 and S_2 touch each other at a point, say, M . Let E_1 be the set representing the locus of M as the pair (S_1, S_2) varies in F_1 . Let the set of all straight line segments joining a pair of distinct points of E_1 and passing through the point $R(1, 1)$ be F_2 . Let E_2 be the set of the mid-points of the line segments in the set F_2 . Then, which of the following statement(s) is(are) TRUE?

(A) The point $(-2, 7)$ lies in E_1

(B) The point $\left(\frac{4}{5}, \frac{7}{5} \right)$ does **NOT** lie in E_2

(C) The point $\left(\frac{1}{2}, 1 \right)$ lies in E_2

(D) The point $\left(0, \frac{3}{2} \right)$ does **NOT** lie in E_1

Ans. [BD]

Sol. Let AM be the common tangent

$$AM = AP = AQ = 2\sqrt{10}$$

⇒ Locus of point M will be a circle with centre (0, 1) and radius $2\sqrt{10}$

$$E_1 : x^2 + (y - 1)^2 = 40 \quad \dots(1)$$

Let BR be the chord to E_1 passing through R and B

is the mid-point, then locus of B is

$$E_2 : x(x - 1) + (y - 1)^2 = 0$$

Equation of chord passing through

$$(1, 1) \text{ and } (-2, 7) \text{ is } 2x + y = 3.$$

Equation of chord passing through

$$(2, -5) \text{ and } (1, 1) \text{ is } 6x + y = 7$$

Chords (2) and (3) are not possible

⇒ $\left(\frac{4}{5}, \frac{7}{5}\right)$ is not lying on E_2 because it is lying on $2x + y = 3$.

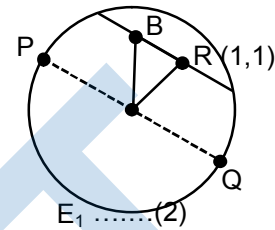
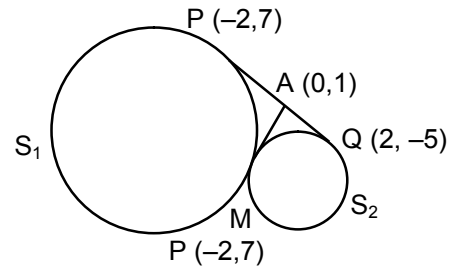

.....(3)

39. Let S be the set of all column matrices $\begin{bmatrix} b_1 \\ b_2 \\ b_3 \end{bmatrix}$ such that $b_1, b_2, b_3 \in \mathbf{R}$ and the system of equations (in real variables)

$$-x + 2y + 5z = b_1$$

$$2x - 4y + 3z = b_2$$

$$x - 2y + 2z = b_3$$

has at least one solution. Then which of the following system(s) (in real variables) has(have) at least

one solution for each $\begin{bmatrix} b_1 \\ b_2 \\ b_3 \end{bmatrix} \in S$?

(A) $x + 2y + 3z = b_1, 4y + 5z = b_2$ and $x + 2y + 6z = b_3$

(B) $x + y + 3z = b_1, 5x + 2y + 6z = b_2$ and $-2x - y - 3z = b_3$

(C) $-x + 2y - 5z = b_1, 2x - 4y + 10z = b_2$ and $x - 2y + 5z = b_3$

(D) $x + 2y + 5z = b_1, 2x + 3z = b_2$ and $x + 4y - 5z = b_3$

Ans. [AD]

Sol. Let $A = \begin{bmatrix} -1 & 2 & 5 \\ 2 & -4 & 3 \\ 1 & -2 & 2 \end{bmatrix}$

$$|A| = \begin{vmatrix} -1 & 2 & 5 \\ 2 & -4 & 3 \\ 1 & -2 & 2 \end{vmatrix} = -1(-8 + 6) - 2(4 - 3) + 5(0)$$

$$= 2 - 2 = 0$$

$$\text{adj}(A) \times B = \begin{bmatrix} -2 & -14 & 26 \\ -1 & -7 & 13 \\ 0 & 0 & 0 \end{bmatrix} \begin{bmatrix} b_1 \\ b_2 \\ b_3 \end{bmatrix} = 0$$

$$= \begin{bmatrix} -2b_1 - 14b_2 + 26b_3 \\ -b_1 - 7b_2 + 13b_3 \\ 0 \end{bmatrix} = 0$$

$$\Rightarrow b_1 + 7b_2 - 13b_3 = 0$$

(A) $|A| \neq 0 \Rightarrow$ Unique solution

(B) $|A| = 0$ and $\text{adj}(A) \cdot B = \begin{bmatrix} 0 & 0 & 0 \\ 3 & 3 & 9 \\ -1 & -1 & -3 \end{bmatrix} \begin{bmatrix} b_1 \\ b_2 \\ b_3 \end{bmatrix} = \begin{bmatrix} 0 \\ 3b_1 + 3b_2 + 9b_3 \\ -b_1 - b_2 - 3b_3 \end{bmatrix}$

(C) $-x + 2y - 5z = b_1$

$$-x + 2y - 5z = \frac{-b_2}{2}$$

$$-x + 2y - 5z = -b_3$$

$$b_1 = \frac{-b_2}{2} = -b_3 \text{ is not satisfy all the condition of } b_1 + 7b_2 = 13b_3.$$

(D) $|A| \neq 0 \Rightarrow$ Unique solution.

40. Consider two straight lines, each of which is tangent to both the circle $x^2 + y^2 = \frac{1}{2}$ and the parabola $y^2 = 4x$. Let these lines intersect at the point P . Consider the ellipse whose centre is at the origin $O(0, 0)$ and whose semi-major axis is OP . If the length of the minor axis of this ellipse is $\sqrt{2}$, then which of the following statement(s) is(are) TRUE ?

(A) For the ellipse, the eccentricity is $\frac{1}{\sqrt{2}}$ and the length of the latus rectum is 1

(B) For the ellipse, the eccentricity is $\frac{1}{2}$ and the length of the latus rectum is $\frac{1}{2}$

(C) The area of the region bounded by the ellipse between the lines $x = \frac{1}{\sqrt{2}}$ and $x = 1$ is $\frac{1}{4\sqrt{2}}(\pi - 2)$

(D) The area of the region bounded by the ellipse between the lines $x = \frac{1}{\sqrt{2}}$ and $x = 1$ is $\frac{1}{16}(\pi - 2)$

Ans. [AC]

Sol. $y = mx + \frac{1}{m}$ is tangent to circle

$$\left| \frac{1}{m\sqrt{1+m^2}} \right| = \frac{1}{\sqrt{2}}$$

$$m^2(1+m^2) = 2$$

$$(m^2 + 2)(m^2 - 1) = 0 \Rightarrow m = \pm 1$$

$$y = x + 1 \text{ and } y = -x - 1$$

intersect at $(-1, 0)$

$$\frac{x^2}{1} + \frac{y^2}{\left(\frac{1}{2}\right)} = 1$$

$$e^2 = 1 \Rightarrow \frac{1}{2} = \frac{1}{2}$$

$$\text{L.L.R.} = \frac{2b^2}{a} = 1 = 1$$

$$\text{Ar} = 2 \int_{1/\sqrt{2}}^1 \frac{1}{\sqrt{2}} \cdot \sqrt{1-x^2} \, dx$$

$$= \sqrt{2} \int_{1/\sqrt{2}}^1 \sqrt{1-x^2} \, dx = \frac{1}{\sqrt{2}} \left(\frac{\pi}{4} - \frac{1}{2} \right)$$

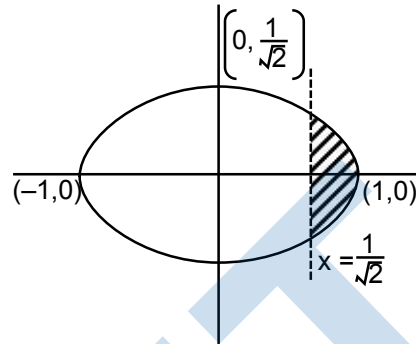

41. Let s, t, r be non-zero complex numbers and L be the set of solutions $z = x + iy$ ($x, y \in \mathbf{R}, i = \sqrt{-1}$) of the equation $sz + t\bar{z} + r = 0$, where $\bar{z} = x - iy$. Then which of the following statement(s) is(are) TRUE?

- (A) If L has exactly one element, then $|s| \neq |t|$
- (B) If $|s| = |t|$, then L has infinitely many elements
- (C) The number of elements in $L \cap \{z : |z - 1 + i| = 5\}$ is at most 2
- (D) If L has more than one element, then L has infinitely many elements

Ans. [ACD]

Sol. $sz + t\bar{z} + r = 0$

$$\bar{s}\bar{z} + \bar{t}z + \bar{r} = 0$$

$$\Rightarrow s\bar{s}z + \bar{s}t\bar{z} + \bar{s}r = 0$$

$$t\bar{s}\bar{z} + t\bar{t}z + t\bar{r} = 0$$

$$z(|s|^2 - |t|^2) + \bar{s}r - t\bar{r} = 0$$

$$z = \frac{t\bar{r} - \bar{s}r}{|s|^2 - |t|^2} \quad |s| \neq |t|$$

42. Let $f : (0, \pi) \rightarrow \mathbf{R}$ be a twice differentiable function such that

$$\lim_{t \rightarrow x} \frac{f(x)\sin t - f(t)\sin x}{t - x} = \sin^2 x \text{ for all } x \in (0, \pi).$$

If $f\left(\frac{\pi}{6}\right) = -\frac{\pi}{4\sqrt{2}}$, then which of the following statement(s) is(are) TRUE?

(A) $f\left(\frac{\pi}{4}\right) = -\frac{\pi}{4\sqrt{2}}$

(B) $f(x) < \frac{x^4}{6} - x^2$ for all $x \in (0, \pi)$

(C) There exists $\alpha \in (0, \pi)$ such that $f'(\alpha) = 0$

(D) $f''\left(\frac{\pi}{2}\right) + f\left(\frac{\pi}{2}\right) = 0$

Ans. [BCD]

Sol. $\lim_{t \rightarrow x} \frac{f(x)\sin t - f(t)\sin x}{t - x}$

$$\lim_{t \rightarrow x} \frac{f(x) \cdot (\sin t - \sin x)}{t - x} + \frac{(f(x) - f(t)) \cdot \sin x}{t - x}$$

$$f(x) \cdot \cos x - f'(x) \sin x = \sin^2 x$$

$$\frac{dy}{dx} - y \cot x = -\sin x$$

$$\frac{y}{\sin x} = -x + c \quad \left(\because f\left(\frac{\pi}{6}\right) = \frac{-\pi}{12} \Rightarrow c = 0 \right)$$

$$y = -x \sin x$$

SECTION 2

43. The value of the integral $\int_0^{1/2} \frac{1 + \sqrt{3}}{\left((x+1)^2(1-x)^6\right)^{1/4}} dx$ is _____.

Ans. [2.00]

Sol. $(\sqrt{3} + 1) \int_0^{1/2} \frac{dx}{(1+x)^2 (1-x)^2}$ put $1 - x = t^2 \Rightarrow -dx = 2t dt$

$$(\sqrt{3} + 1) \int_{\frac{1}{\sqrt{2}}}^1 \frac{2t}{(2-t^2)^2 \cdot t^3} dt$$

$$2(\sqrt{3} + 1) \int_{\frac{1}{\sqrt{2}}}^1 \frac{dt}{(2t^2 - 1)^2 \cdot t^2 \cdot t} \quad \text{put } 2t^2 - 1 = y^2 \Rightarrow \frac{-4}{t^3} dt = 2y dy$$

$$= -(\sqrt{3} + 1) \int_{\sqrt{3}}^1 \frac{-y}{y} dy = -(\sqrt{3} + 1)(1 - \sqrt{3}) = 2 \text{ Ans.}$$

44. Let P be a matrix of order 3×3 such that all the entries in P are from the set $\{-1, 0, 1\}$. Then the maximum possible value of the determinant of P is _____.

Ans. [4.00]

Sol.
$$\begin{vmatrix} a_1 & a_2 & a_3 \\ b_1 & b_2 & b_3 \\ c_1 & c_2 & c_3 \end{vmatrix} = a_1 (b_2 c_3 - b_3 c_2) - a_2 (b_1 c_3 - b_3 c_1) + a_3 (b_1 c_2 - b_2 c_1)$$

$$= a_1 b_2 c_3 + a_2 b_3 c_1 + a_3 b_1 c_2 - a_1 b_3 c_2 - a_2 b_1 c_3 - a_3 b_2 c_1$$

$$\Rightarrow a_1 = 1, a_2 = 1, a_3 = 1; b_1 = -1, b_2 = 1, b_3 = -1; c_1 = -1, c_2 = -1, c_3 = 1$$

$$\begin{vmatrix} a_1 & a_2 & a_3 \\ b_1 & b_2 & b_3 \\ c_1 & c_2 & c_3 \end{vmatrix} = 1 + 1 + 1 - 1 - (-1) - (-1) = 4. \text{ Ans.}$$

45. Let X be a set with exactly 5 elements and Y be a set with exactly 7 elements. If α is the number of one-one functions from X to Y and β is the number of onto functions from Y to X, then the value of

$$\frac{1}{5!} (\beta - \alpha) \text{ is } \underline{\hspace{2cm}}.$$

Ans. [119.00]

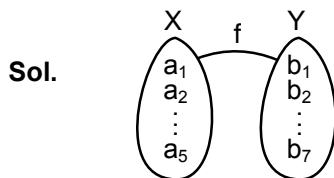

$$\alpha = {}^7C_5 \cdot 5! = \frac{7 \cdot 6}{2 \cdot 1} \cdot 5! = \frac{7!}{2}$$

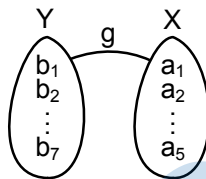

$$7 = \begin{bmatrix} 1, 1, 1, 1, 3 \\ 1, 1, 1, 2, 2 \end{bmatrix}$$

$$\beta = \left(\frac{7!}{4! \cdot 3!} + \frac{7!}{3! \cdot (2!) \cdot 2!} \right) \times 5! = \left(\frac{7 \cdot 6 \cdot 5}{3} + \frac{7 \cdot 6 \cdot 5 \cdot 4}{8} \right) \cdot 5!$$

$$= 35 \times 4 \times 5! = \frac{7 \cdot 5 \cdot 4 \cdot 3}{3} \times 5! = \frac{10}{3} \times 7!$$

$$\therefore \beta - \alpha = \left(\frac{10}{3} \times 7 \cdot 6 - \frac{7 \cdot 6}{2} \right) \cdot 5! \Rightarrow \frac{1}{5!} (\beta - \alpha) = 119.00 \text{ Ans.}$$

46. Let $f : \mathbf{R} \rightarrow \mathbf{R}$ be a differentiable function with $f(0) = 0$. If $y = f(x)$ satisfies the differential equation

$$\frac{dy}{dx} = (2 + 5y)(5y - 2),$$

then the value of $\lim_{x \rightarrow -\infty} f(x)$ is _____.

Ans. [0.40]

Sol. $\frac{1}{4} \int \left(\frac{1}{5y-2} - \frac{1}{5y+2} \right) dy = dx$

$$\frac{1}{4} \cdot \frac{1}{5} \ln \left| \frac{5y-2}{5y+2} \right| = x + C$$

$x = 0 = y$

$\therefore C = 0$

$$\Rightarrow \frac{2-5y}{2+5y} = e^{20x} \Rightarrow \frac{2+5y}{2-5y} = \frac{1}{e^{20x}} \Rightarrow \frac{10y}{4} = \frac{1-e^{20x}}{1+e^{20x}} \Rightarrow y = \frac{2}{5} \left(\frac{1-e^{20x}}{1+e^{20x}} \right)$$

$$\lim_{x \rightarrow -\infty} y = \lim_{x \rightarrow -\infty} \frac{2}{5} \left(\frac{1-e^{20x}}{1+e^{20x}} \right) = \frac{2}{5} = 0.40. \text{ Ans.}$$

47. Let $f: \mathbf{R} \rightarrow \mathbf{R}$ be a differentiable function with $f(0) = 1$ and satisfying the equation

$$f(x+y) = f(x)f'(y) + f'(x)f(y) \text{ for all } x, y \in \mathbf{R}.$$

Then, the value of $\log_e(f(4))$ is _____.

Ans. [2.00]

Sol. $f(x+y) = f(x)f'(y) + f'(x)f(y)$

$$x = y = 0 \Rightarrow f'(0) = \frac{1}{2}$$

$$\text{Putting } y = 0, f(x) = \frac{f(x)}{2} + f'(x) \Rightarrow f'(x) = \frac{f(x)}{2}$$

$$\ln f(x) = \frac{x}{2} + C; x = 0, f(0) = 1 \Rightarrow C = 0$$

$$f(x) = e^{\frac{x}{2}}$$

$$\ln(f(4)) = 2. \text{ Ans.}$$

48. Let P be a point in the first octant, whose image Q in the plane $x + y = 3$ (that is, the line segment PQ is perpendicular to the plane $x + y = 3$ and the mid-point of PQ lies in the plane $x + y = 3$) lies on the z -axis. Let the distance of P from the x -axis be 5. If R is the image of P in the xy -plane, then the length of PR is _____.

Ans. [8.00]

Sol. Let P be (α, β, γ)

Image of P lies on z -axis

$$\therefore Q \equiv (0, 0, \gamma)$$

PQ is perpendicular to the plane $x + y = 3$

$$\therefore \frac{\alpha}{1} = \frac{\beta}{1} = \frac{0}{0} = k$$

Mid-point PQ lies on the plane $x + y = 3$

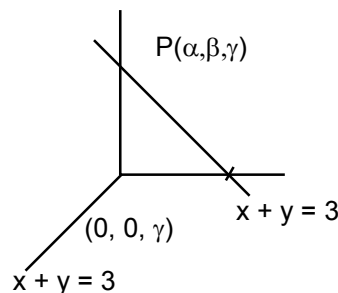

$$\therefore \frac{\alpha}{2} + \frac{\beta}{2} = 3 \Rightarrow k = 3$$

$$\text{Distance of P from x-axis} \Rightarrow \sqrt{\beta^2 + \gamma^2} = 5 \Rightarrow 9 + \gamma^2 = 25 \Rightarrow \gamma = 4.$$

Image of P in the x-y plane is R (α , β , $-\gamma$)

$$\therefore PR = 2\gamma = 8.$$

49. Consider the cube in the first octant with sides OP, OQ and OR of length 1, along the x-axis, y-axis and z-axis, respectively, where O(0, 0, 0) is the origin. Let $S\left(\frac{1}{2}, \frac{1}{2}, \frac{1}{2}\right)$ be the centre of the cube and T be the vertex of the cube opposite to the origin O such that S lies on the diagonal OT. If $\vec{p} = \vec{SP}, \vec{q} = \vec{SQ}, \vec{r} = \vec{SR}$ and $\vec{t} = \vec{ST}$ then the value of

$$|(\vec{p} \times \vec{q}) \times (\vec{r} \times \vec{t})| \text{ is } \underline{\hspace{2cm}}.$$

Ans. [0.50]

$$\text{Sol. } \vec{SP} = \vec{p} = \frac{\hat{i}}{2} - \frac{\hat{j}}{2} - \frac{\hat{k}}{2};$$

$$\vec{SQ} = \vec{q} = \frac{\hat{i}}{2} + \frac{\hat{j}}{2} - \frac{\hat{k}}{2};$$

$$\vec{SR} = \vec{r} = -\frac{\hat{i}}{2} - \frac{\hat{j}}{2} + \frac{\hat{k}}{2};$$

$$\vec{ST} = \vec{t} = \frac{\hat{i}}{2} + \frac{\hat{j}}{2} + \frac{\hat{k}}{2}$$

$$= (\vec{p} \times \vec{q}) \times (\vec{r} \times \vec{t}) = [\vec{p} \ \vec{r} \ \vec{t}] \vec{q} - [\vec{q} \ \vec{r} \ \vec{t}] \vec{p}$$

$$[\vec{p} \ \vec{r} \ \vec{t}] = \begin{vmatrix} \frac{1}{2} & -\frac{1}{2} & -\frac{1}{2} \\ -\frac{1}{2} & -\frac{1}{2} & \frac{1}{2} \\ \frac{1}{2} & \frac{1}{2} & \frac{1}{2} \end{vmatrix} = \frac{1}{8} \begin{vmatrix} 1 & -1 & -1 \\ -1 & -1 & 1 \\ 1 & 1 & 1 \end{vmatrix} = \frac{1}{8} \begin{vmatrix} 0 & -2 & 0 \\ 0 & 0 & 2 \\ 1 & 1 & 1 \end{vmatrix} = \frac{1}{8} (-4) = -\frac{1}{2}$$

$$[\vec{q} \ \vec{r} \ \vec{t}] = \begin{vmatrix} -\frac{1}{2} & \frac{1}{2} & -\frac{1}{2} \\ -\frac{1}{2} & -\frac{1}{2} & \frac{1}{2} \\ \frac{1}{2} & \frac{1}{2} & \frac{1}{2} \end{vmatrix} = \frac{1}{8} \begin{vmatrix} -1 & 1 & -1 \\ -1 & -1 & 1 \\ 1 & 1 & 1 \end{vmatrix} = \frac{1}{8} \begin{vmatrix} -2 & 0 & 0 \\ 0 & 0 & 2 \\ 1 & 1 & 1 \end{vmatrix} = \frac{1}{2}$$

$$(\vec{p} \times \vec{q}) \times (\vec{r} \times \vec{t}) = \frac{-\vec{q}}{2} - \frac{\vec{p}}{2} = \frac{-(\vec{p} + \vec{q})}{2} = \frac{-(-\hat{k})}{2} = \frac{\hat{k}}{2}.$$

$$\therefore |(\vec{p} \times \vec{q}) \times (\vec{r} \times \vec{t})| = \frac{1}{2} = 0.50.$$

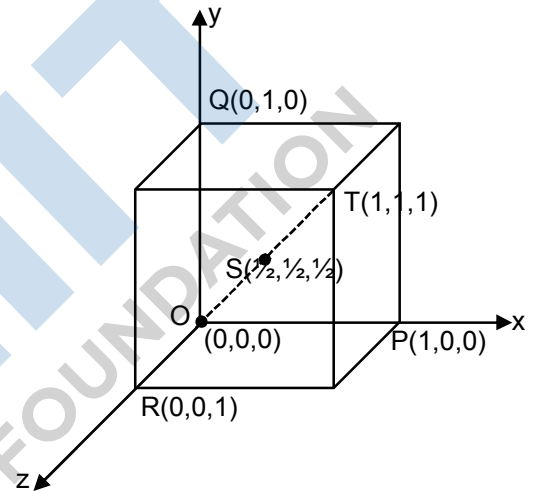

50. Let $X = \binom{10}{0}C_1^2 + 2\binom{10}{1}C_2^2 + 3\binom{10}{2}C_3^2 + \dots + 10\binom{10}{9}C_{10}^2$, where $\binom{10}{r}C_r$, $r \in \{1, 2, \dots, 10\}$ denote binomial coefficients. Then, the value of $\frac{1}{1430}X$ is _____.

Ans. [646.00]

Sol. $X = 0 \cdot \binom{10}{0}C_0^2 + 1 \cdot \binom{10}{1}C_1^2 + 2 \cdot \binom{10}{2}C_2^2 + \dots + 10 \cdot \binom{10}{10}C_{10}^2$

$X = 0 \cdot \binom{10}{0}C_0^2 + 9 \cdot \binom{10}{1}C_1^2 + 2 \cdot \binom{10}{2}C_2^2 + \dots + 0 \cdot \binom{10}{10}C_{10}^2$

$2X = 10 [(\binom{10}{0}C_0)^2 + (\binom{10}{1}C_1)^2 + \dots + (\binom{10}{10}C_{10})^2]$

$2X = 10 \cdot {}^{20}C_{10}$

$X = 5 \cdot \frac{20!}{10! \cdot 10!} = 5 \frac{11 \cdot 12 \cdot 13 \cdot 14 \cdot 15 \cdot 16 \cdot 17 \cdot 18 \cdot 19 \cdot 20}{1 \cdot 2 \cdot 3 \cdot 4 \cdot 5 \cdot 6 \cdot 7 \cdot 8 \cdot 9 \cdot 10}$

$X = 11 \cdot 13 \cdot 17 \cdot 19 \cdot 20 = 1430 \times 17 \times 19 \times 2$

$\Rightarrow \frac{X}{1430} = 646.00$ Ans.

SECTION 3

51. Let $E_1 = \{x \in \mathbf{R} : x \neq 1 \text{ and } \frac{x}{x-1} > 0\}$

and $E_2 = \{x \in E_1 : \sin^{-1}\left(\log_e\left(\frac{x}{x-1}\right)\right) \text{ is a real number}\}.$

(Here, the inverse trigonometric function $\sin^{-1}x$ assumes values in $\left[-\frac{\pi}{2}, \frac{\pi}{2}\right].$)

Let $f : E_1 \rightarrow \mathbf{R}$ be the function defined by $f(x) = \log_e\left(\frac{x}{x-1}\right)$

and $g : E_2 \rightarrow \mathbf{R}$ be the function defined by $g(x) = \sin^{-1}\left(\log_e\left(\frac{x}{x-1}\right)\right).$

List-I

List-II

(P) The range of f is

(1) $\left(-\infty, \frac{1}{1-e}\right] \cup \left[\frac{e}{e-1}, \infty\right)$

(Q) The range of g contains

(2) $(0, 1)$

(R) The domain of f contains

(3) $\left[-\frac{1}{2}, \frac{1}{2}\right]$

(S) The domain of g is

(4) $(-\infty, 0) \cup (0, \infty)$

(5) $\left(-\infty, \frac{e}{e-1}\right]$

$$(6) \quad (-\infty, 0) \cup \left(\frac{1}{2}, \frac{e}{e-1}\right]$$

The correct option is:

(A) $P \rightarrow 4; Q \rightarrow 2; R \rightarrow 1; S \rightarrow 1$

(B) $P \rightarrow 3; Q \rightarrow 3; R \rightarrow 6; S \rightarrow 5$

(C) $P \rightarrow 4; Q \rightarrow 2; R \rightarrow 1; S \rightarrow 6$

(D) $P \rightarrow 4; Q \rightarrow 3; R \rightarrow 6; S \rightarrow 5$

Ans. [A]

Sol. $E_1 : x \in (-\infty, 0) \cup (1, \infty)$

$$E_2 : -1 \leq \ln \left(\frac{x}{x-1} \right) \leq 1$$

$$\frac{1}{e} \leq \frac{x}{x-1} \leq e$$

$$\frac{x}{x-1} - \frac{1}{e} \geq 0 \Rightarrow \frac{ex - x + 1}{x-1} \geq 0$$

$$\Rightarrow \frac{x(e-1)+1}{x-1} \geq 0$$

$$x \in \left(-\infty, -\frac{1}{e-1}\right] \cup (1, \infty)$$

$$\frac{x}{x-1} - e \leq 0 \Rightarrow \frac{x - ex + e}{x-1} \leq 0$$

$$\Rightarrow \frac{x(e-1) - e}{x-1} \geq 0$$

$$\Rightarrow x \in (-\infty, 1) \cup \left[\frac{e}{e-1}, \infty\right)$$

$$\therefore E_2 : \left(-\infty, \frac{-1}{e-1}\right] \cup \left[\frac{e}{e-1}, \infty\right)$$

(P) $\frac{x}{x-1} \in (0, \infty) - \{1\}$

\therefore Range of f is $(-\infty, 0) \cup (0, \infty)$

(Q) $g(x) = \sin^{-1}(f(x))$

\therefore Range of $g(x)$ is $\left[-\frac{\pi}{2}, 0\right) \cup \left(0, \frac{\pi}{2}\right]$

(R) Domain of f is E_1

$$E_1 \text{ contains } \left(-\infty, \frac{-1}{e-1}\right] \cup \left[\frac{e}{e-1}, \infty\right)$$

(S) Domain of g is E_2

$$E_2 \text{ contains } \left(-\infty, \frac{1}{1-e}\right] \cup \left[\frac{e}{e-1}, \infty\right)$$

52. In a high school, a committee has to be formed from a group of 6 boys $M_1, M_2, M_3, M_4, M_5, M_6$ and 5 girls G_1, G_2, G_3, G_4, G_5 .

- (i) Let α_1 be the total number of ways in which the committee can be formed such that the committee has 5 members, having exactly 3 boys and 2 girls.
- (ii) Let α_2 be the total number of ways in which the committee can be formed such that the committee has at least 2 members, and having an equal number of boys and girls.
- (iii) Let α_3 be the total number of ways in which the committee can be formed such that the committee has 5 members, at least 2 of them being girls.
- (iv) Let α_4 be the total number of ways in which the committee can be formed such that the committee has 4 members, having at least 2 girls and such that both M_1 and G_1 are **NOT** in the committee together.

List-I

- (P) The value of α_1 is
- (Q) The value of α_2 is
- (R) The value of α_3 is
- (S) The value of α_4 is

List-II

- (1) 136
- (2) 189
- (3) 192
- (4) 200
- (5) 381
- (6) 461

The correct option is:

- (A) $P \rightarrow 4; Q \rightarrow 6; R \rightarrow 2; S \rightarrow 1$
- (B) $P \rightarrow 1; Q \rightarrow 4; R \rightarrow 2; S \rightarrow 3$
- (C) $P \rightarrow 4; Q \rightarrow 6; R \rightarrow 5; S \rightarrow 2$
- (D) $P \rightarrow 4; Q \rightarrow 2; R \rightarrow 3; S \rightarrow 1$

Ans. [C]

Sol.

(P) $\alpha_1 = {}^6C_3 \times {}^5C_2 = 200$
 (1B and 1G) + (2B and 2G) + (3B and 3G) + (4B and 4G) + (5B and 5G)

(Q) $\alpha_2 = {}^6C_1 \times {}^5C_1 + {}^6C_2 \times {}^5C_2 + {}^6C_3 \times {}^5C_3 + {}^6C_4 \times {}^5C_4 + {}^6C_5 \times {}^5C_5$
 $= 30 + 150 + 200 + 75 + 6$
 $= 461$

(R) $\alpha_3 = {}^{11}C_5 - ({}^6C_4 \times {}^5C_1 + {}^6C_5) = 381$

(S) $\alpha_4 = {}^5C_2 \times {}^6C_2 + {}^5C_3 \times {}^6C_4 + {}^5C_4 - ({}^4C_2 + {}^4C_1 \times {}^5C_1)$
 $= 150 + 60 + 5 - (6 + 20) = 189.$

53. Let $H : \frac{x^2}{a^2} - \frac{y^2}{b^2} = 1$, where $a > b > 0$, be a hyperbola in the xy-plane whose conjugate axis LM subtends an angle of 60° at one of its vertices N. Let the area of the triangle LMN be $4\sqrt{3}$.

- List-I**
- (P) The length of the conjugate axis of H is
 - (Q) The eccentricity of H is
 - (R) The distance between the foci of H is
 - (S) The length of the latus rectum of H is

- List-II**
- (1) 8
 - (2) $\frac{4}{\sqrt{3}}$
 - (3) $\frac{2}{\sqrt{3}}$
 - (4) 4

The correct option is:

(A) $P \rightarrow 4; Q \rightarrow 2; R \rightarrow 1; S \rightarrow 3$

(B) $P \rightarrow 4; Q \rightarrow 3; R \rightarrow 1; S \rightarrow 2$

(C) $P \rightarrow 4; Q \rightarrow 1; R \rightarrow 3; S \rightarrow 2$

(D) $P \rightarrow 3; Q \rightarrow 4; R \rightarrow 2; S \rightarrow 1$

Ans. [B]

Sol. $\frac{b}{a} = \frac{1}{\sqrt{3}} \Rightarrow a = \sqrt{3}b$

$$\frac{\sqrt{3}}{4}(4b^2) = 4\sqrt{3}$$

$b = 2 \therefore a = 2\sqrt{3}$

$P \rightarrow 2b = 4$

$Q \rightarrow c = \sqrt{1 + \frac{b^2}{a^2}} = \sqrt{1 + \frac{1}{3}} = \frac{2}{\sqrt{3}}$

$R \rightarrow 2ae = 2 \cdot 2\sqrt{3} \cdot \frac{2}{\sqrt{3}} = 8$

$S \rightarrow \frac{2b^2}{a} = 2 \cdot \frac{4}{2\sqrt{3}} = \frac{4}{\sqrt{3}}$

Option (B) is correct.

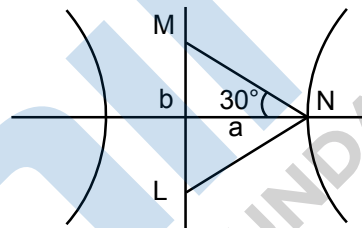

54. Let $f_1 : \mathbf{R} \rightarrow \mathbf{R}$, $f_2 : \left(-\frac{\pi}{2}, \frac{\pi}{2}\right) \rightarrow \mathbf{R}$, $f_3 : (-1, e^{\pi/2} - 2) \rightarrow \mathbf{R}$ and $f_4 : \mathbf{R} \rightarrow \mathbf{R}$ be functions defined by

(i) $f_1(x) = \sin\left(\sqrt{1 - e^{-x^2}}\right),,$

(ii) $f_2(x) = \begin{cases} |\sin x| & \text{if } x \neq 0 \\ \tan^{-1} x & \text{if } x = 0 \end{cases}$, where the inverse trigonometric function $\tan^{-1} x$ assumes values in

$$\left(-\frac{\pi}{2}, \frac{\pi}{2}\right),$$

(iii) $f_3(x) = [\sin(\log_e(x+2))]$, where, for $t \in \mathbf{R}$, $[t]$ denotes the greatest integer less than or equal to t ,

(iv) $f_4(x) = \begin{cases} x^2 \sin\left(\frac{1}{x}\right) & \text{if } x \neq 0 \\ 0 & \text{if } x = 0 \end{cases}$

- | List-I | List-II |
|---------------------------|--|
| (P) The function f_1 is | (1) NOT continuous at $x = 0$ |
| (Q) The function f_2 is | (2) continuous at $x = 0$ and NOT differentiable at $x = 0$ |
| (R) The function f_3 is | (3) differentiable at $x = 0$ and its derivative is NOT continuous at $x = 0$ |
| (S) The function f_4 is | (4) differentiable at $x = 0$ and its derivative is continuous at $x = 0$ |

The correct option is:

- | | |
|--|--|
| (A) $P \rightarrow 2; Q \rightarrow 3; R \rightarrow 1; S \rightarrow 4$ | (B) $P \rightarrow 4; Q \rightarrow 1; R \rightarrow 2; S \rightarrow 3$ |
| (C) $P \rightarrow 4; Q \rightarrow 2; R \rightarrow 1; S \rightarrow 3$ | (D) $P \rightarrow 2; Q \rightarrow 1; R \rightarrow 4; S \rightarrow 3$ |

Ans. [D]

Sol.

(P) $f_1 : \mathbb{R} \rightarrow \mathbb{R}$

$$f_1(x) = \sin(\sqrt{1-e^{-x^2}}) \text{ Continuous at } x = 0$$

For derivability at $x = 0$

$$f_1'(0^+) = \lim_{h \rightarrow 0} \frac{\sin \sqrt{1-e^{-h^2}} - 0}{h}$$

$$f_1'(0^-) = \lim_{h \rightarrow 0} \frac{\sin \sqrt{1-e^{-h^2}} - 0}{-h} = -1$$

$$= \lim_{h \rightarrow 0} \sqrt{\frac{1-e^{-h^2}}{h^2}} = 1 \quad \text{Continuous but non-derivative.}$$

(Q) $f_2 : \left(-\frac{\pi}{2}, \frac{\pi}{2}\right) \rightarrow \mathbb{R}$

$$f_2(x) = \begin{cases} \frac{|\sin x|}{\tan^{-1} x} & \text{if } x \neq 0 \\ 1 & \text{if } x = 0 \end{cases}$$

$f_2(x)$ discontinuous at $x = 0$.

$Q \rightarrow 1$.

(R) $f_3 : (-1, e^{\pi/2} - 2) \rightarrow \mathbb{R}$

$$f_3(x) = [\sin(\log(x+2))] \quad -1 < x < e^{\pi/2} - 2$$

$$f_3(x) = 0 \quad 1 < x + 2 < e^{\pi/2}$$

$f_3(x)$ is continuous and derivable. $0 < \ln(x+2) < \frac{\pi}{2}$

$R \rightarrow 4$. $0 < \sin(\ln(x+2)) < 1$.

(S) $f_4 : \mathbb{R} \rightarrow \mathbb{R}$

$$f_4(x) = \begin{cases} x^2 \sin\left(\frac{1}{x}\right) & x \neq 0 \\ 0 & x = 0 \end{cases}$$

Clearly $f_4(x)$ is derivable at $x = 0$ but its derivative is **NOT** continuous at $x = 0$.

S \rightarrow 3

MENIIT
NEET | IIT-JEE | FOUNDATION